

**Air Heaters**

**Workshop Manual**

## **Air Top 2000 STC**

Trade names:

Air Top 2000 STC B (petrol)

Air Top 2000 STC D (diesel)



Improper installation or repair of Webasto heating and cooling systems can cause fire or the leakage of deadly carbon monoxide leading to serious injury or death.

To install and repair Webasto heating and cooling systems you need to have completed a Webasto training course and have the appropriate technical documentation, special tools and special equipment.



Only genuine Webasto parts may be used. See also Webasto air and water heaters accessories catalogue.

NEVER try to install or repair Webasto heating or cooling systems if you have not completed a Webasto training course, you do not have the necessary technical skills and you do not have the technical documentation, tools and equipment available to ensure that you can complete the installation and repair work properly.

ALWAYS carefully follow Webasto installation and repair instructions and heed all WARNINGS.

Webasto rejects any liability for problems and damage caused by the system being installed by untrained personnel.

---

**Table of Contents**

<b>1</b>	<b>Introduction</b>	<b>101</b>
1.1	Contents and purpose	101
1.1.1	Use of air heaters	101
1.2	Meaning of signal words	101
1.2.1	General safety information	101
<b>2</b>	<b>General description</b>	<b>201</b>
2.1	Drive unit	201
2.2	Heat exchanger	202
2.3	Burner with combustion chamber	202
2.4	Control unit	202
2.5	Flame monitor (petrol heater only)	202
2.6	Glow plug	203
2.7	Overheating sensor	203
2.8	Fuel pump	203
<b>3</b>	<b>Functional description</b>	<b>301</b>
3.1	Control element	301
3.2	Switching on	301
3.3	Heating mode	301
3.4	Control mode	301
3.5	Control pause	301
3.6	Switching off	302
3.7	Heater functions in ADR vehicles	302
3.8	Fault switch-off	302
3.8.1	Fault monitoring	303
3.8.2	Resetting fault switch-off	303
<b>4</b>	<b>Technical data</b>	<b>401</b>
4.1	General technical data	401
4.1	Setpoints	402
<b>5</b>	<b>Troubleshooting</b>	<b>501</b>
5.1	General information	501
5.2	General fault symptoms	501
5.3	Fault symptoms during operation	502
5.4	Fault code output (hexadecimal / Webasto Thermo Test)	503
5.5	Fault code output (flashing or FXX output)	506
<b>6</b>	<b>Function checks</b>	<b>601</b>
6.1	General information	601
6.2	Required test and measuring equipment	601
6.3	Settings	603
6.3.1	Setting the CO <sub>2</sub> content	603
6.3.2	CO <sub>2</sub> setting for reference heater	603
6.4	Testing individual components	604

6.4.1	Component: burner	605
6.4.2	Testing resistance of flame monitor (petrol heater only)	606
6.4.3	Component: glow plug	608
6.4.4	Component: drive unit	610
6.4.5	Component: overheating temperature sensor	611
6.4.6	Component: control unit	612
6.4.7	Component: heater	613
<b>7</b>	<b>Wiring diagrams</b>	<b>701</b>
7.1	General information	701
7.2	System wiring diagrams	702
7.3	Legends to system wiring diagrams	704
7.4	Pin assignments plug connection X6, 18-pin	705
<b>8</b>	<b>Servicing</b>	<b>801</b>
8.1	General information	801
8.2	Working on the heater	801
8.3	Working on the vehicle	801
8.4	Heater test run	801
8.5	Servicing	801
8.6	Visual inspection and installation requirements	801
8.6.1	Heating air system	801
8.6.2	Fuel supply	802
8.6.2.1	Fuel take-off, general	802
8.6.2.2	Permissible fuel pressure fuel line lengths	802
8.6.2.3	Fuel take-off via tank drain plug (from plastic or metal fuel tank)	803
8.6.2.4	Webasto tank extracting device for plastic fuel tank	803
8.6.2.5	Webasto tank extracting device for metal tank	803
8.6.2.6	Fuel lines	803
8.6.2.7	Connecting 2 fuel lines with a hose	804
8.6.3	Fuel pump	804
8.6.3.1	Installation location	804
8.6.3.2	Installation and attachment	804
8.6.4	Fuel filter	805
8.6.5	Combustion air supply	805
8.6.6	Exhaust line	805
8.6.7	Exhaust silencer	805
8.6.8	Combustion air intake and exhaust pipes	806
8.6.9	Electrical Connections	806
8.6.9.1	Heater and control element connection	806
8.6.9.2	Supply voltage connection	806
8.6.9.3	Control element connection	807
8.7	Removing and installing	809
8.7.1	Removing and installing heater	809
8.7.1.1	Removal	809
8.7.1.2	Installation	809
8.8	Commissioning	809

<b>9</b>	<b>Repair</b>	<b>901</b>
9.1	General information	901
9.1.1	Work on stripped down components	901
9.1.1.1	Cleaning	901
9.1.1.2	Visual inspection	901
9.1.2	Carrying out modifications	901
9.1.2.1	Installing of an external room temperature sensor	901
9.2	Dismantling and assembling	902
9.2.1	Removing casing parts	902
9.2.1.1	Cover for electrical connection	902
9.2.1.2	Grille for heating air inlet and outlet	902
9.2.1.3	Cover for heating air inlet and outlet	902
9.2.1.4	Upper casing	902
9.2.1.5	Lower casing	902
9.2.2	Fitting the casing parts	902
9.2.2.1	Lower casing	902
9.2.2.2	Upper casing	902
9.2.2.3	Cover for heating air inlet and outlet	902
9.2.2.4	Grille for heating air inlet and outlet	902
9.2.2.5	Cover for electrical connection	902
9.2.3	Replacing control unit	904
9.2.3.1	Removal	904
9.2.3.2	Installation	904
9.2.4	Replacing the overheating temperature sensor	904
9.2.4.1	Removal	904
9.2.4.2	Installation	904
9.2.5	Replacing drive unit (drive motor, combustion air fan and intake housing)	904
9.2.5.1	Removal	904
9.2.5.2	Installation	904
9.2.6	Replacing flame monitor (petrol heater only)	905
9.2.6.1	Removal	905
9.2.6.2	Installation	905
9.2.7	Changing glow plug	907
9.2.7.1	Removal	907
9.2.7.2	Installation	907
9.2.8	Replacing burner, combustion chamber and heat exchanger	909
9.2.8.1	Removal	909
9.2.8.2	Installation	909
<b>10</b>	<b>Packaging/storage and shipping</b>	<b>1001</b>
10.1	General information	1001

## Table of Illustrations

Fig. 201	Air heater Air Top 2000 STC	201
Fig. 202	Air Top 2000 STC air heater without casing	201
Fig. 203	Drive unit	201
Fig. 204	Heat exchanger	202
Fig. 205	Burner with combustion chamber	202
Fig. 206	Control unit	202
Fig. 207	Flame monitor	202
Fig. 208	Glow plug	203
Fig. 209	Overheating sensor	203
Fig. 210	Fuel pump DP42 (petrol)	203
Fig. 211	Fuel pump DP42 (diesel) with diaphragm damper	203
Fig. 401	Technical Data Air Top 2000 STC	401
Fig. 402	Setpoints Air Top 2000 STC	402
Fig. 501	General fault symptoms	501
Fig. 502	Fault symptoms during operation	502
Fig. 603	Component overview	602
Fig. 601	Characteristic resistance values of an overheating temperature sensor	611
Fig. 701	Connector assignments	701
Fig. 702	System wiring diagram Air Top 2000 STC, 12 V/24 V with rotary switch	702
Fig. 703	Systems wiring diagram Air Top 2000 STC, 12 V/24 V with MultiControl	702
Fig. 704	System wiring diagram Air Top 2000 STC D, 12 V/24 V ADR operation with SmartControl	703
Fig. 705	System wiring diagram Air Top 2000 STC D, 12 V/24 V ADR operation with rotary switch	703
Fig. 706	System wiring diagram Air Top 2000 STC, 12 V/24 V with combination timer	704
Fig. 801	Fuel line lengths, inside diameter and height differences (fuel tank, heater) to fuel pump	802
Fig. 802	Fuel take-off via tank drain plug (plastic or metal fuel tank)	803
Fig. 803	Webasto tank extracting device (plastic fuel tank)	803
Fig. 804	Webasto tank extracting device (metal fuel tank)	803
Fig. 805	Pipe/hose connections	804
Fig. 806	DP42 fuel pump (installation position, petrol)	804
Fig. 807	DP42 fuel pump, installation position, diesel	804
Fig. 808	Fuel filter	805
Fig. 809	Exhaust silencer	805
Fig. 810	End of exhaust pipe, installation position	806
Fig. 811	Removing mounting plate on fuse holder	806
Fig. 812	Fuse holder, installation position	806
Fig. 813	Rotary switch control element	807
Fig. 814	Disconnecting the connector	807
Fig. 815	Installation example of heater in recirculated air mode	808
Fig. 901	Installing an external room temperature sensor	901
Fig. 902	Removing / fitting casing parts	903
Fig. 903	Replacing control unit, combustion air fan and overheating temperature sensor	906
Fig. 904	Changing glow plug, replacing flame monitor, burner and heat exchanger	908
Fig. 905	Starting air hole in burner	910

## 1 Introduction

### 1.1 Contents and purpose

This workshop manual is designed to assist trained personnel in repairing both the petrol and the diesel versions of the Air Top 2000 STC air heaters.

#### 1.1.1 Use of air heaters

The Webasto Air Top 2000 STC air heaters are designed:

- to heat cabins, boats, commercial vehicles, minibusses, vans/transporters, ambulances and motor homes.
- to defrost vehicle windows.

They are not approved for heating cargo areas used to carry dangerous goods/hazardous substances.

The heaters operate independently of the engine and are connected directly to the fuel tank and the electrical system of the vehicle.

They may be used for vehicles with either water or air-cooled engines.

### 1.2 Meaning of signal words

Throughout this manual, the signal words CAUTION, ATTENTION and NOTE have the following meanings:

#### CAUTION

This signal word is used to highlight operating instructions or procedures which, if not followed or not followed correctly, may result in personal injury or fatal accidents.

#### ATTENTION

This signal word is used to highlight operating instructions or procedures which, if not followed or not followed correctly, may result in damage to the equipment or its components.

#### NOTE

This signal word is used to draw your attention to a special feature.

#### 1.2.1 General safety information

The mouth of the exhaust pipe should be installed facing downwards, to the side or, if the exhaust pipe passes under the floor of the vehicle, up to the side or rear limit of the driver's cab or of the vehicle.

The function of important parts of the vehicle must not be adversely affected. It must not be possible for condensation or water to collect in the exhaust pipe. Drain holes may be used.

The electrical cables, switchgear and control units for the heater must be arranged in the vehicle such that their function is not impaired under normal operating conditions.

Compliance with §§ 45 and 46 StVZO (German road vehicle registration regulation) must be ensured for the installation of fuel lines and the installation of additional fuel tanks. The main points of this regulation:

- Fuel lines must be designed in such a way that torsion in the vehicle, engine movements and similar do not have a negative effect on their durability. They must be protected from mechanical damage.
- Parts that carry fuel must be protected from heat that could adversely affect their function and positioned such that dripping or evaporating fuel cannot collect or ignite on hot parts or on electrical equipment.

**The heat exchanger of the air heater can be used for a maximum period of 10 years and must then be replaced with a genuine spare part by the manufacturer or an authorised workshop. A label must then be affixed to the heater showing the date of sale and the wording "Genuine Spare Part".**

When you change the heat exchanger it is also necessary that you replace the overheating protection element (overheating sensor) to prevent possible malfunctions caused by using the old overheating sensor.

The Air Top 2000 STC heaters are prepared for interior installation and are sealed directly on the driver's cab floor or wall. Non-release connections must be used in the interior for combustion air and exhaust pipes for Webasto accessories.

The seal between the heater mounting and the vehicle floor must always be installed otherwise harmful exhaust gases may get into the vehicle interior.

The heating air and combustion air intake openings must be positioned in such a way that no water can enter them when the vehicle is driven through water at permissible levels.

The heater must not be installed in the driver's or passenger's compartment of busses (vehicle class M<sub>2</sub> and M<sub>3</sub>). If the heater is nevertheless installed in such a place, the casing must be tightly sealed from the vehicle interior. The casing must have sufficient external ventilation to ensure a maximum temperature of 40 °C is not exceeded in the box. Faults may occur if the temperature exceeds this level.

Due to the risk of explosion, the heater must be switched off at filling stations and facilities.

Due to the risk of explosion, the heater must be switched off wherever inflammable vapours or dust can form (e.g. in the vicinity of fuel, coal, wood dust or grain stores or similar).

Due to the risk of asphyxiation and poisoning, the heater must not be operated in enclosed areas such as garages and workshops without an emissions extraction system even if you use the timer.

In the event of prolonged smoke accumulation, unusual combustion noise or smell of fuel, the heater must be shut down by removing the fuse and must not be started again until it has been examined by Webasto-trained personnel. Liability claims can only be asserted for proven compliance with the maintenance and safety information by the claimant.

Installation regulations for Webasto fuel tanks for supplying fuel to heaters in vehicles:

- The tanks must not be installed in the passenger's compartment or driver's cab of busses.
- The fuel filler neck must not be inside the passenger's compartment or driver's cab in any vehicle.
- Petrol fuel tanks must not be installed directly behind the front panelling of the vehicle. They must be separated from the engine in such a way that in the event of an accident the fuel cannot ignite. This does not apply to tractor units with an open driver's seat.

Due to the potential fire risk, the fuel lines (Mecanyl hose) must not make direct contact with the exhaust pipe and must be thermally insulated wherever necessary.

All fuel pipes must have sealed connections, they must not be damaged in any way and must be checked at regular intervals (at least at the same intervals as the vehicle inspection).

### NOTE

If any damage or leaks are found on the fuel line, the heater must not be used until the damage has been rectified by an authorised Webasto workshop.

Put the heater out of action by removing the fuse.

### Overheating

Keep the heating air inlet and heating air outlet free of dirt and foreign objects. Dirty, blocked air lines can cause the heater to shut down due to overheating.

After the heater has shut down due to overheating, check that the air system is clear, remove any materials that may block the air flow and have any damage to the air lines repaired by an authorised Webasto workshop. The heater lock-out can then be cancelled by switching the heater off and on again. If this action does not produce the required success (if the heater overheats again), take it to a Webasto authorised workshop. Never remove the grill over the air inlet of the heater.

The air outlet jets or air vents with adjustable flaps must always be opened by a certain extent so that the air flow through the heater is not completely blocked. At least one air vent must be unclosable.

If the heater is installed in a storage area you must ensure that no flammable substances are kept in this area and that other material does not restrict the air supply to the heater.

Air lines must be securely fixed to the heater (pipe clips) and all other connection points (vents).

### ATTENTION

The points described below must be avoided:

- Do not step on the heater and do not place or throw any heavy objects onto the heater.
- Do not place any items of clothing, fabrics or similar materials over the heater or in front of the heating air intake side and the heating air outlet.
- The flow of hot air from the heater must not be restricted or blocked by highly flammable substances or materials such as rags, cleaning wool etc.
- Flammable or explosive substances and gasses must not be placed near or in contact with the heater, the hot air line, the hot air flow or the exhaust pipe.
- The heater must not be cleaned with a high-pressure cleaner.
- Do not frequently switch off the heater at the main battery switch or battery disconnecter otherwise the heater may suffer long-term damage and malfunctions.

### NOTE

Failure to follow the installation instructions and the notes contained therein will lead to all liability being refused by Webasto.

The same applies if repairs are carried out incorrectly or with the use of parts other than genuine spare parts. This will result in the invalidation of the type approval for the heater and therefore of its homologation / EC type licence.

Carefully read the operating instructions before operating the heater.



Page for notes

### 2 General description

The Air Top 2000 STC air heater is based on the evaporator principle and essentially consists of:

- Drive unit (combustion air fan, heating air fan and drive motor)
- Heat exchanger
- Burner with combustion chamber
- Control unit
- Glow plug
- Housing parts
- Base seal

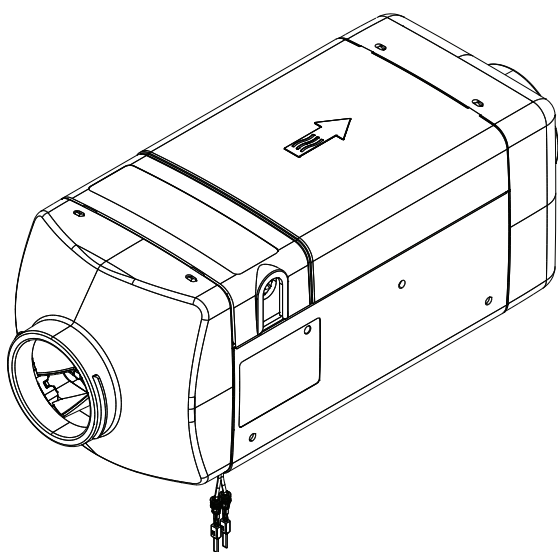

Fig. 201 Air heater Air Top 2000 STC

The following control and monitoring components are integrated in the heater:

- Control unit with room temperature sensor
- Flame monitor (petrol heater only)
- Glow plug
- Overheating sensor

All Air Top 2000 STC heaters can also be controlled using an optional external room temperature sensor.

The fuel is supplied from the external fuel tank by a fuel pump.

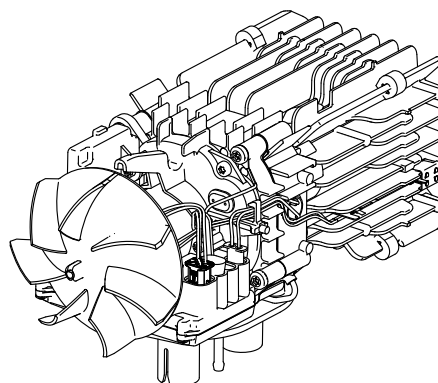

Fig. 202 Air Top 2000 STC air heater without casing

#### 2.1 Drive unit

The drive unit consists of the drive motor, combustion air fan, heating air fan and the intake casing.

The combustion air fan supplies the air required for the combustion process through the combustion air inlet into the combustion chamber.

The heating air fan feeds the hot air from the hot air inlet via the heat exchanger to the hot air outlet.

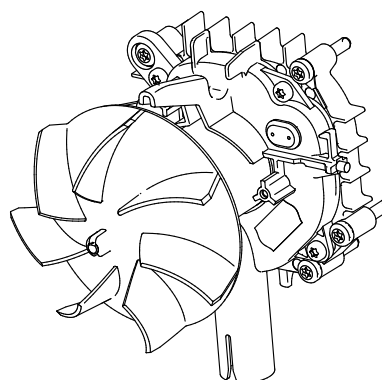

Fig. 203 Drive unit

**2.2 Heat exchanger**

In the heat exchanger, the heat generated by the combustion process is transferred to the air delivered by the heating air fan.

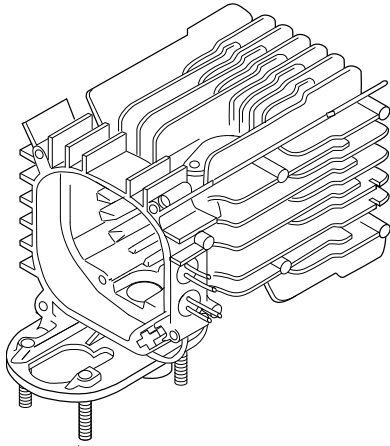

Fig. 204 Heat exchanger

**2.3 Burner with combustion chamber**

In the burner, the fuel is distributed over the metal fibre evaporator (mesh) in the combustion chamber. The fuel/air mixture burns in the combustion chamber, thus heating the heat exchanger.

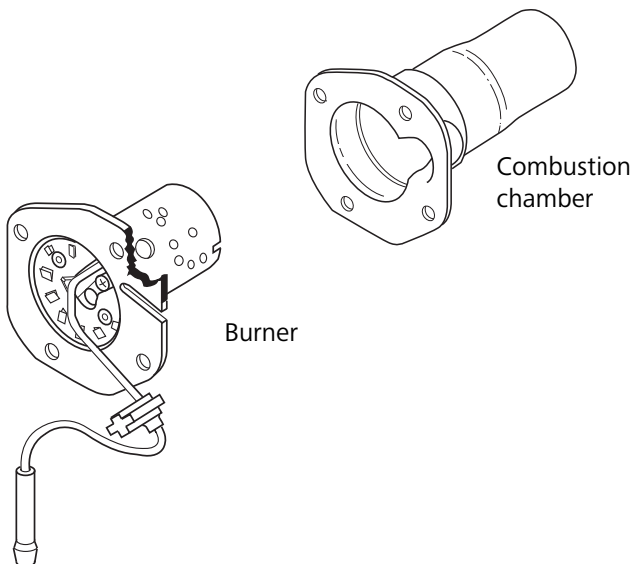

Fig. 205 Burner with combustion chamber

**2.4 Control unit**

The control unit is the central component for ensuring trouble-free operation. It monitors the components, evaluates the sensor signals and controls heating operation.

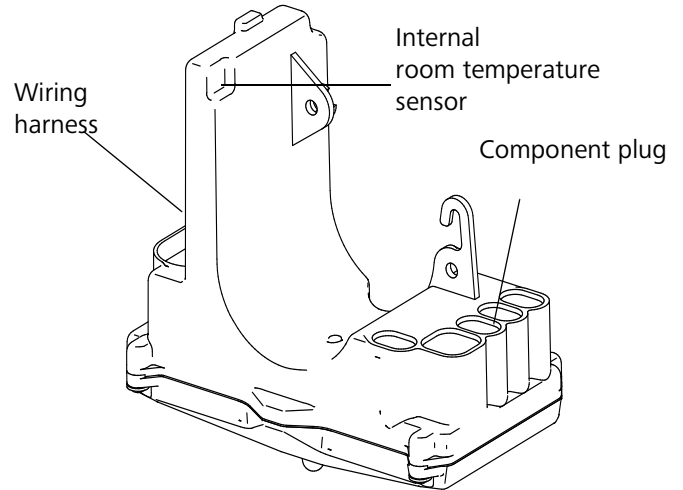

Fig. 206 Control unit

**2.5 Flame monitor (petrol heater only)**

The flame monitor is a low-impedance PTC resistor which changes its resistance as a function of the heat emitted by the flame. This change in resistance is evaluated by the control unit so that the flame status is monitored throughout the heating operation.

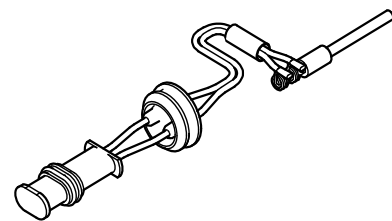

Fig. 207 Flame monitor

**2.6 Glow plug**

The fuel/air mixture is ignited by the glow plug when the heater is started. The glow plug is designed as an electrical resistor and is positioned in the burner on the side opposite the flame.

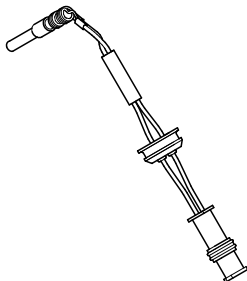

Fig. 208 Glow plug

**2.7 Overheating sensor**

The overheating sensor measures the temperature in the fin area of the heat exchanger while the heater is operating. The control unit evaluates the signal, regulates the heating air outlet temperature and controls the overheating shut-down function.

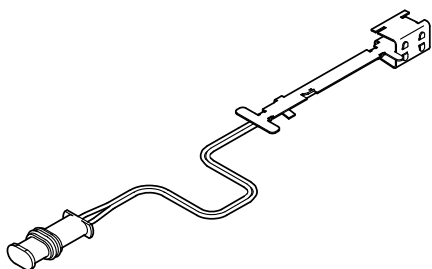

Fig. 209 Overheating sensor

**2.8 Fuel pump**

The fuel pump is a combined delivery, metering and a shut-off system for supplying fuel to the heater. The Air Top 2000 STC heater must be operated with the fuel pump DP 42.

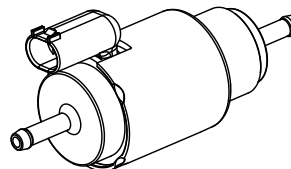

Fig. 210 Fuel pump DP42 (petrol)

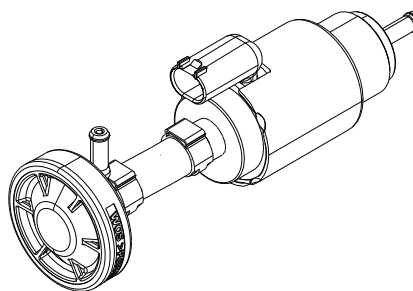

Fig. 211 Fuel pump DP42 (diesel) with diaphragm damper

Page for notes

### 3 Functional description

#### 3.1 Control element

The control element is used to:

- Switch the heater on and off.
- Set the required room temperature (intake temperature between approx. 5 °C and 35 °C).
- Reset the heater after a malfunction.
- Display fault codes:
  - Control elements with display: the fault code is shown on the display.
  - Control elements without display: the fault code is indicated by the indicator lamp flashing in defined sequences.

#### NOTE

##### ADR operation:

The heater is in ADR lock-out mode after an ADR shutdown. This mode is cancelled after switching the heater off and on again.

#### 3.2 Switching on

Set the control element to the required temperature.

The heater will start up if the heating air temperature is lower than the set temperature.

#### NOTE

Only the heating air fan will start up if the room temperature is higher than the set temperature. The heating air fan will not start up if an external room temperature sensor is connected.

The flame monitor is checked. If the flame monitor now signals "light", the system will attempt to cool the flame monitor for 60 seconds. If the flame monitor still signals "light" the control unit will be locked out. If there is a malfunction in any another monitored component fault lock-out will take place with no afterrunning period.

#### Start

When the heater is switched on, the ON indicator lamp comes on and the glow plug is switched on (clocked). The motor of the heating and combustion air fan is set to approx. 50% of its maximum speed.

The fuel pump starts after approx. 40 seconds and the flame begins to form. To improve the starting characteristics, the fuel pump and the combustion air fan are started at different frequencies and speeds.

After a further 95 seconds (petrol) or 110 seconds (diesel) the glow plug is switched off and the presence of a flame established.

#### Automatic restart

The starting procedure will be repeated if no flame is detected. The glow plug is switched on again (clocked). The motor of the heating and combustion air fan is set to approx. 25% of its maximum speed.

The fuel pump starts after approx. 30 seconds (petrol) or 50 seconds (diesel) and the flame begins to form. After a further 65 seconds (petrol) or 90 seconds (diesel) the glow plug is switched off and the presence of a flame established.

If the heater again fails to ignite properly, after a 180 second fault afterrun phase at maximum speed the heater will be shut down and is in fault lock-out mode.

#### NOTE

The heater will assume fault lock-out mode after a restart. Briefly switch the heater off and on (for at least 2 seconds) to reset fault lock-out.

#### 3.3 Heating mode

Combustion gasses flow through the heat exchanger during heater operation. The combustion heat is transferred to the walls of the heat exchanger, absorbed by the heating air blown in by the heating air fan and blown into the vehicle interior.

The temperature of the heating air intake is measured by a room temperature sensor on the intake side of the heater or an external room temperature sensor. If the measured temperature is lower than the value set on the control element, the heating capacity will be increased to maximum.

To extend the service life of the burner the delivery rate from the fuel pump is reduced for 10 seconds every 10 minutes during continuous operation.

In addition, heating mode is interrupted every 8 hours in the same way as for a control pause.

#### 3.4 Control mode

In control mode, the speed of the heating and combustion air fan and the fuel pump delivery rate are dependent on the heating capacity. The glow plug is switched off.

#### 3.5 Control pause

The heating capacity is reduced on reaching the temperature set on the control element. The speed of the heating and combustion air fan and the delivery rate of the fuel pump are reduced.

If, at minimum heating capacity, the intake temperature set on the control element is exceeded, the fuel pump will be shut down and combustion stops. To allow the flame to burn out properly, the speed of the heating and combustion air fan drops to partial load speed after 20 seconds, returns to the initial speed after 15 seconds and then drops to the control pause speed after 3 minutes where it remains during the entire control pause phase.

The control pause speed for boat heaters is 0. The heater will restart if the temperature at the room temperature sensor drops below the set temperature.

#### NOTE

Changes to the settings on the control element are implemented by the control unit/heater with a time delay.

### 3.6 Switching off

The ON indicator lamp on the control element goes out when the heater is switched off. If no fuel has yet been delivered or if the heater is in control pause mode, the heater will be switched off immediately with no afterrunning period. If fuel delivery has already begun it will stop immediately when the heater is switched off. The heater is switched off in the same way as the transition from control mode to control pause. The heater is then switched off automatically.

#### NOTE

It is possible to switch the heater back on during the afterrunning period. In this case, afterrunning is completed and the heater is then restarted.

### 3.7 Heater functions in ADR vehicles

#### NOTE

Only for Air Top 2000 STC diesel heaters that are installed in vehicles for transporting dangerous goods (ADR):

Afterrunning period will remain unchanged if the heater is switched off at the control element.

A brief afterrunning period (max. 40 seconds) is started automatically when:

- The vehicle's engine is shut down
- A pumping device is placed into operation.

The control unit is in "fault lock-out" mode after an ADR shut-down. The control element must be set to "OFF" before starting up again.

### 3.8 Fault switch-off

The control unit detects faults in individual heater components and malfunctions during start-up and operation. The heater shuts down and assumes fault lock-out when:

- No repeated or faulty start-up
- Room temperature sensor defective
- Overheating sensor interrupted or short-circuited
- Overheating sensor installed incorrectly
- Glow plug interrupted or short-circuited
- Drive motor overloaded or blocked or short-circuited or interrupted
- Flame monitor interrupted or short circuited
- Fault in fuel pump electrical circuit or in overheating protection (only during start phase)
- Undervoltage below 10.5 V/21 V for longer than 20 seconds
- Overvoltage above 16 V/32 V for longer than 6 seconds
- Control unit defective

The fuel supply shuts down in the event of overheating. The heater continues to run (afterrunning period) as when switched off manually. Following the afterrunning period the control unit is in fault lock-out mode if the count of the overheating counter is greater than the value programmed in the data set (currently 20).

- Control element with display: the overheating fault code is shown on the display.
- Control element without display: the overheating fault code is indicated by the operating indicator flashing in defined sequences.

Rectify fault.

Briefly switch the heater on and off (for at least 2 seconds) to reset fault lock-out.

### 3.8.1 Fault monitoring

Overheating, incorrect start and flame failure faults are counted and, after the maximum number of permissible faults have been exceeded, result in heater lock-out.

The incorrect start counter is incremented by 1 each time the heater fails to start and decremented by 1 each time it starts correctly, but never falls below 0. If the incorrect start counter reaches the maximum permissible value of 7, this indicates that the heater is in heater lock-out mode (HGVP).

The fault counter is incremented by 1 for each malfunction, which does not have its own counter. The fault counter is reset to 0 at the start of control mode. If the fault counter reaches the maximum permissible value of 10, this indicates that the heater is in heater lock-out mode.

The overheating counter is incremented by 1 each time the heater overheats. If the overheating counter reaches the maximum permissible value of 20, this indicates that the heater is in heater lock-out mode.

The flame interruption counter (FAZ) is incremented by 1 each time the flame fails during heating mode. The counter is decremented by 1 each time the heater assumes control mode.

If the flame interruption counter reaches a value of 3 the heater will assume fault lock-out mode and the permanent flame interruption counter is incremented by 1. In control mode, the permanent flame interruption counter is decremented by 1. When the heater is burning properly again, the permanent flame interruption counter will return to 0 after a few control cycles. If the permanent flame interruption counter exceeds the maximum permissible value of 3, the heater will assume heater lock-out mode.

### 3.8.2 Resetting fault switch-off

1. **Switch on the heater**  
↓
2. There is a fault and it is detected by the control unit as a **malfunction**  
↓
3. The **fault code** is shown on the control element  
↓
4. If set, cancel **heater lock-out** (as described in the following)  
↓
- 4.1. The heater detects a fault as a **malfunction**  
↓
- 4.2. **Fault switch-off** followed by **fault lock-out**  
↓
- 4.3. The **fault code** is shown on the control element  
↓
5. Switch off the heater  
↓
6. Determine cause of fault (e.g. with or without **fault code**, visual inspection of fuses and plug connections, ...)  
↓
7. Rectify fault  
↓
8. Switch on the heater  
↓
9. Reset **fault lock-out**  
↓
10. The heater assumes control mode

Certain faults add to the fault count in the fault code memory. The heater assumes heater lock-out mode when the number of faults in the fault code memory exceeds a limit value. The maximum number of fault in the fault code memory and the limit value of the fault code memory is defined by Webasto.

#### Reset heater lock-out

Heater lock-out can be reset:

- With Webasto Thermo Test PC diagnostics (WTT)
- or by switching on the heater.  
Pull fuse **F1** for at least 10 s.  
Switch off the heater.  
Reinsert fuse **F1**.  
Switch on the heater.

#### Reset permanent heater lock-out

Only for "OE" heater variants that are integrated in bus systems.

The lock-out can only be released with the vehicle-specific computer diagnosis system.



Page for notes

4 Technical data

Wherever no limit values are specified, the technical data in the table refer to the standard heater tolerances of ±10% at an ambient temperature of +20 °C and at rated voltage under standard conditions.

**Electrical components:**

The control unit, drive motor for heating air and combustion air fan as well as the glow plug are designed for 12 Volt or 24 Volt.

The temperature sensor and flame monitor (only petrol heater) are not designed for specific voltages.

**Fuel for Air Top 2000 STC B (petrol):**

The fuel in accordance with DIN EN 228 as specified by the vehicle manufacturer should be used.

**Fuel for Air Top 2000 STC D (diesel/FAME):**

The diesel fuel in accordance with DIN EN590 specified by the vehicle manufacturer must be used. Class EL fuel oil (not L fuel oil) can also be used provided it complies with the normal quality as per DIN 51603 available in the German market. There are no known adverse effects of using additives.

If fuel is taken from the vehicle's fuel tank, follow the additive instructions issued by the vehicle manufacturer.

When changing to low-temperature fuel, the heater must be

4.1 General technical data

Heater	Operation	Air Top 2000 STC B	Air Top 2000 STC D
Type approval	EMC Heater	E1 R10- 04 1085 E1 R122- 00 0216	
Design		Air heater with evaporator burner	
Heat flow	Control range	1.0 - 2.0 kW	0.9 - 2.0 kW
Fuel		Petrol DIN EN 228 DIN 51625	Diesel/FAME DIN EN 590 DIN 51603 DIN EN 14214
Fuel consumption	Control range	0.1 - 0.2 kg/h (0.14 - 0.27 l/h)	0.1 - 0.21 kg/h (0.12 - 0.24 l/h)
Rated voltage		12 Volt	12 / 24 Volt
Operating voltage range		10.5 - 16 Volt	10.5 - 16 / 20.5 - 31 Volt
Rated power consumption	Control range	14-29 W	
Permissible ambient temperature: Heater: - Operation - Storage Fuel pump: - Operation - Storage		-40 to + 40 °C -40 to + 85 °C -40 to + 20 °C (petrol), -40 to + 30 °C (diesel), -40 to + 85 °C	
Permissible combustion air intake temperature		-40 to + 20 °C	
Adjustment range for interior temperature	Control range	+5 to + 35 °C	
Volumetric heating air flow rate at motor speed	at 0.5 mbar	max. 93 m <sup>3</sup> /h at 4750 U/min	
CO <sub>2</sub> in exhaust gas (permitted function range)	1 kW 2 kW	5.0 - 8.0 % 9.0 - 12.5 %	5.0 ... 8.0 % 9.0 ... 12.5 %
Heater dimensions		Length 311 ± 2 mm Width 120 ± 1 mm Height 121 ± 1 mm	
Weight		2.6 kg	

Fig. 401 Technical Data Air Top 2000 STC

## 4.1 Setpoints

Heater	Operation	Air Top 2000 STC B and Air Top 2000 STC D	
		12 Volt	24 Volt
Glow plug	At 25 °C Test current: < 5 mA	Red mark 0.263 - 0.323 Ohm	Green mark 1.125 - 1.375 Ohm
Drive motor	Outside	< 6 Ohm	
Overheating temperature sensor	at 25 °C	2 - 2.5 Ohm	
Undervoltage shut-down (tripping time > 20 s)		≤ 10.5 V	≤ 20.5 V
Overvoltage shut-down (tripping time > 6 s)		≥ 15 V	≥ 31 V
Flame monitor (cold test)	At 25 °C Test current: < 5 mA	2.6 - 3.4 Ohm	
Flame monitor (hot test)	At 800 – 1000 °C Test current: < 5 mA (ceramic rod red-hot over approx. 20 mm length)	12 - 15 Ohm	

Fig. 402 Setpoints Air Top 2000 STC

Page for notes

## 5 Troubleshooting

### 5.1 General information

This section describes how to identify and remedy faults in the Air Top 2000 STC heater.

If a malfunction occurs, a fault code will be shown on the display or the ON indicator lamp will flash (on control elements with no display). The heater can be additionally checked with a personal computer (see operating instructions for Webasto Thermo Test PC Diagnostics).

#### ATTENTION

Troubleshooting assumes detailed knowledge of the design and functional principle of the individual heater components and must only be carried out by specifically trained personnel.

If in doubt, refer to Section 2 and 3 for information on how the functions interact.

#### NOTE

##### For ADR operation only

The control unit is in "fault lock-out" mode after an ADR shutdown or the operating voltage has been applied by switching on the main switch in the vehicle and setting the control element to ON. Before restarting the heater, the control element must be set to "OFF" or the Quick Heat button on the combination timer pressed.

#### ATTENTION

Troubleshooting is generally restricted to locating faulty components. The following potential sources of malfunction are not taken into account as they should always be checked to rule them out as the cause of fault:

- **Corroded connectors**
- **Loose plug connectors**
- **Poor crimp contacts on connectors**
- **Corroded cables and fuses**
- **Corroded battery terminals**

The electrical plug connections at the control unit must be disconnected to check individual components.

Carry out a function check in the vehicle after rectifying after each fault.

### 5.2 General fault symptoms

The following table (Fig. 501) lists the possible fault symptoms.

Fault symptom	Possible cause	Corrective measures
Heater cuts out automatically	No combustion after start and restart ON indicator lamp flashes  Flame goes out during operation ON indicator lamp flashes  Heater overheating ON indicator lamp flashes  Battery voltage too low ON indicator lamp flashes	Briefly switch heater off and on again  Briefly switch heater off and on again  Check heating air routing for free passage, allow heater to cool, briefly switch heater off and on again  Charge battery Briefly switch heater off and on again
Heater emits black smoke	Combustion air and/or exhaust system blocked	Check combustion-air and exhaust-gas routing for free passage

Fig. 501 General fault symptoms

### 5.3 Fault symptoms during operation

The following table (Fig. 502) lists the possible fault symptoms during operation which should be checked first. In the event of a malfunction, the fault is to be located and rectified with the aid of this table. It is important to ensure that the fault symptom is clearly identified.

If the fault symptom is not included in this table, or if the malfunction cannot be found under the specific fault symptom, the fault can be determined by means of the fault codes as described in the following tables (Section 5.4 and 5.5).

In an emergency you can contact our technicians on our Service Hotline.

Fault symptom	Occurrence	Possible cause
Heater will not start and LED on control element not lit	Immediate	Incorrect wiring, defective fuse
Heater will not start, but LED lit	Immediate	The heater immediately assumes control pause mode when switched on; the control pause speed for a boat heater is 0 rpm.

Fig. 502 Fault symptoms during operation

#### NOTE

A fault code can be shown as follows:

- MultiControl and SmartControl control element:  
The malfunction is shown in the form of a fault code which begins with F and a hexadecimal combination of numbers and/or letters (F HEX).  
**See "5.4 Fault code output (hexadecimal / Webasto Thermo Test)" on Page 503.**
- Control elements with display (not MultiControl/SmartControl):  
The malfunction is shown in the form of a fault code which begins with F and a two-number combination (FXX).  
**See "5.5 Fault code output (flashing or FXX output)" on Page 506.**
- Control elements with indicator lamp:  
the malfunction is indicated in the form of a flash code. After 5 fast flash pulses, the fault code is output by a sequence of long flash pulses. The long flash pulses must be counted.  
**See "5.5 Fault code output (flashing or FXX output)" on Page 506.**

## 5.4 Fault code output (hexadecimal / Webasto Thermo Test)

Fault code output:	Fault message	Fault details	Recommended measures
HEX			
00	No error	No error	No action necessary
01	Defective control unit	Defective control unit, wrong end-of-line programming or coolant temperature sensor (at water heaters) failure	Replace control unit
02	No start	After start-up has been repeated, combustion still fails to occur	1) Check for fault in air intake and exhaust systems 2) Check for fault in fuel system 3) Check fuel pump 4) Electrical check of glow plug
03	Flame failure	The flame went out during operation and combustion.	See error 02
04	Supply Voltage too high	Supply voltage was too long above maximum threshold value	Check system voltage
05	Flame was detected prior to combustion	Flame detector signals flame before combustion operation	1) Check for fault in air intake, exhaust systems 2) Check for fault in fuel system 3) Check fuel pump 4) Electrical check of glow plug
06	Heating unit overheated	Overheat protection has been activated or the temperature at the heat exchanger has exceeded the upper limit	1) Check for fault in air intake/blow-out side, exhaust systems 2) Check for fault in fuel system
07	Heater lock-out	Heater interlocked	1) Reset heater lock-out and attempt restart 2) Read out further fault messages and work through instructions Reset heater lock-out: switch on heater. Pull fuse F1 for at least 10 s. Switch off heater. Reinsert fuse F1. Switch on the heater. <b>NOTE</b> Following fault occurred several times: Fault counter: > 10x False start counter: > 7x Overheating counter: > 20x
08	Fuel pump short circuit	Fuel pump has short circuit to ground	Electrical check of fuel system
09	Combustion air fan short circuit	Combustion air fan has short circuit to ground	Electrical check of combustion air fan motor
11	Wrong fuel coding	Incorrect parameter block or wrong heater (diesel/gasoline) used	Replace control unit

Fault code output:	Fault message	Fault details	Recommended measures
HEX			
12	W-bus communication failure	W-Bus communication failure	1) Check for fault in area of W-bus communication/W-bus control element/W-bus Telestart 2) Replace control unit
14	Temperature sensor short circuit (internal, external)	Temperature sensor has short circuit to ground	Electrical check of external/internal temperature sensor
15	Combustion air fan blocked	Combustion air fan is blocked	1) Check for fault in fan motor 2) Heating air intake fan wheel snagging or jammed 3) Combustion air intake fan wheel snagging or jammed
17	Gradient exceedance overheat protection	The temperature rise at the heat exchanger has exceeded the upper limit.	Check for fault in air intake/blow-out side, exhaust systems
18	Communication failure on customer specific bus	Communication failure on customer specific bus	-
19	Glow plug / flame monitor short circuit	Glow plug / electronic ignition unit has short circuit to ground	Electrical check of glow plug
81	EOL checksum error	Checksum of EOL dataset is wrong	Replace control unit
82	No start during test-run	No start during test-run	See error 02
83	Flame failure	Flame interruption during combustion operation, more than FAZ (EEPROM) times.	See error 02
84	Operating voltage too low	Supply voltage was too long below maximum threshold value	Check system voltage
88	Fuel pump interruption	Fuel pump interrupted or short circuit to supply voltage UB	Electrical check of fuel system
89	Combustion air fan interruption	Combustion air fan interrupted or short circuit to supply voltage UB	Electrical check of fan motor
91	Wrong control unit coding	Control unit locked or coded as neutral	Replace control unit
92	Command refresh failure	Command refresh failure	Check for fault in area of W-bus communication/W-bus control element/W-bus Telestart
94	Temperature sensor interruption (internal, external)	Temperature sensor interrupted or short circuit to supply voltage UB	Electrical check of external/internal temperature sensor
97	Gradient undershooting during start	Overheat sensor position wrong (temperatur gradient too low)	1) Check position of overheating sensor 2) Check fuel supply system
99	Glow plug / electronic ignition unit interruption	Glow plug / electronic ignition unit interrupted or short circuit to supply voltage UB	Electrical check of glow plug
0 A	Glow plug / flame monitor short circuit	Glow plug/Flame monitor circuit has short circuit to ground	Electrical check of glow plug
1 A	Flame sensor short circuit	Flame sensor has short circuit to ground	Electrical check of flame monitor



<b>Fault code output:</b>	<b>Fault message</b>	<b>Fault details</b>	<b>Recommended measures</b>
<b>HEX</b>			
<b>1B</b>	Overheat sensor short circuit	The overheat sensor has a short circuit to ground	Electrical check of overheating sensor
<b>8 A</b>	Glow plug / electronic ignition unit interruption	Glow plug/Flame monitor interrupted or short circuit to supply voltage UB	Electrical check of glow plug
<b>9 A</b>	Flame sensor interruption	Flame sensor interrupted or short circuit to supply voltage UB	Electrical check of flame monitor
<b>9B</b>	Setpoint potentiometer interruption	Setpoint potentiometer interrupted or short circuit to supply voltage UB	Electrical check of setpoint sensor
<b>AB</b>	Overheat sensor interruption	Overheat sensor interrupted or short circuit to supply voltage UB	Electrical check of overheating sensor

## 5.5 Fault code output (flashing or FXX output)

Fault code output:	Fault message	Fault details	Recommended measures
Flashing / FXX			
<b>F00</b>	Defective control unit	Control unit defective EOL programming error	1) Check for fault in area of W-bus communication/W-bus control element/W-bus Telestart 2) Replace control unit
<b>F01</b>	No start	No flame formed even after repeated start attempt	1) Check for fault in air intake and exhaust systems 2) Check for fault in fuel system 3) Check fuel pump 4) Electrical check of glow plug
<b>F02</b>	Flame failure	The flame goes out during operation and no longer reformed after a restart attempt.	See error 01
<b>F03</b>	Supply Voltage too high	The operating voltage was higher than the maximum permissible value for too long	Check system voltage
<b>F04</b>	Flame was detected prior to combustion	The flame monitor detected a flame before combustion started	1) Check for fault in air intake, exhaust systems 2) Check for fault in fuel system 3) Check fuel pump 4) Electrical check of glow plug
<b>F05</b>	Flame sensor interruption	There is a break or short to UB in the electrical circuit of the flame detector	Electrical check of flame monitor
<b>F06</b>	Temperature sensor interruption (internal, external)	There is a break or short to UB in the temperature sensor	Electrical check of external/internal temperature sensor
<b>F07</b>	Fuel pump interruption	There is a break or short to UB in the electrical circuit of the fuel pump	Electrical check of fuel system
<b>F08</b>	Combustion air fan short circuit	The combustion air fan has a short to ground or the fan motor is overloaded	Electrical check of combustion air fan motor
	Combustion air fan blocked	Combustion air fan blocking guard has tripped	1) Check for fault in fan motor 2) Heating air intake fan wheel snagging or jammed 3) Combustion air intake fan wheel snagging or jammed
<b>F09</b>	Glow plug / electronic ignition unit interruption	There is a break or short to UB in the glow plug/ignition spark generator	Electrical check of glow plug
<b>F10</b>	Heating unit overheated	Overheating lock-out has tripped (heater overheated)	1) Check for fault in air intake/blow-out side, exhaust systems 2) Check for fault in fuel system
<b>F11</b>	Overheat sensor interruption	There is a break or short to UB in the electrical circuit of the overheating sensor	Electrical check of overheating sensor

Fault code output: Flashing / FXX	Fault message	Fault details	Recommended measures
<b>F12</b>	Heater lock-out	Heater lock-out was activated	1) Reset heater lock-out and attempt restart 2) Read out further fault messages and work through instructions Reset heater lock-out: switch on heater. Pull fuse F1 for at least 10 s. Switch off heater. Reinsert fuse F1. Switch on the heater. <b>NOTE</b> Following fault occurred several times: Fault counter: > 10x False start counter: > 7x Overheating counter: > 20x
<b>F14</b>	Gradient undershooting during start	Wrong position of overheating sensor (overheating sensor gradient too small)	1) Check position of overheating sensor 2) Check fuel supply system
<b>F15</b>	Setpoint potentiometer interruption	There is a break or short to UB in the electrical circuit of the setpoint potentiometer	Electrical check of setpoint sensor

Page for notes

## 6 Function checks

### 6.1 General information

This section describes the checks conducted on the heater in installed and uninstalled state to verify that it is in working order.

#### CAUTION

The heater must not be operated in enclosed areas such as garages and workshops without an emissions extraction system.

#### ATTENTION

The complete testing of the heater and the control unit test for "OEM" heaters are only possible together with the vehicle.

### 6.2 Required test and measuring equipment

The test and measuring equipment must be calibrated and measuring equipment suitability must be certified.

#### Digital multimeter

For measuring electrical resistance [ohms], electrical continuity

≤ 0.1 ohms

Test current < 5 mA

#### Voltage source, adjustable

Supplies electrical voltage [Volt]

10 - 30 V

≥ 30 A

#### CO<sub>2</sub> measuring device

For checking CO<sub>2</sub> value [vol%]

Maximum ±0.3 vol%

#### PC (personal computer)

System requirements:

- See operating instructions for WTT Diagnostics
- Information can be found at [dealers.webasto.com](http://dealers.webasto.com)

#### Webasto diagnostics adapter including Webasto Thermo Test software.

Diagnostic adapter Ident.-No. 9009064\_ is available from Webasto.

Display of fault code memory, operating data, control unit information.

#### Reference heater Air Top 2000 STC 24V diesel

The reference heater must be continually monitored.

#### Heater test bench



Example of heater test bench

For checking heater operation

Contact for Webasto heater test bench: International Technical Support - International Hotline:  
hotline.wt@webasto.com

A schematic diagram of the components necessary to operate a heater is shown below.

Application-specific interfaces must be taken into account. A calibrated fuel pump, which is continually monitored, must be used for testing. The technical requirements are specified in the Webasto product documentation. Webasto components should preferably be used. Pay particular attention to occupational health and safety.

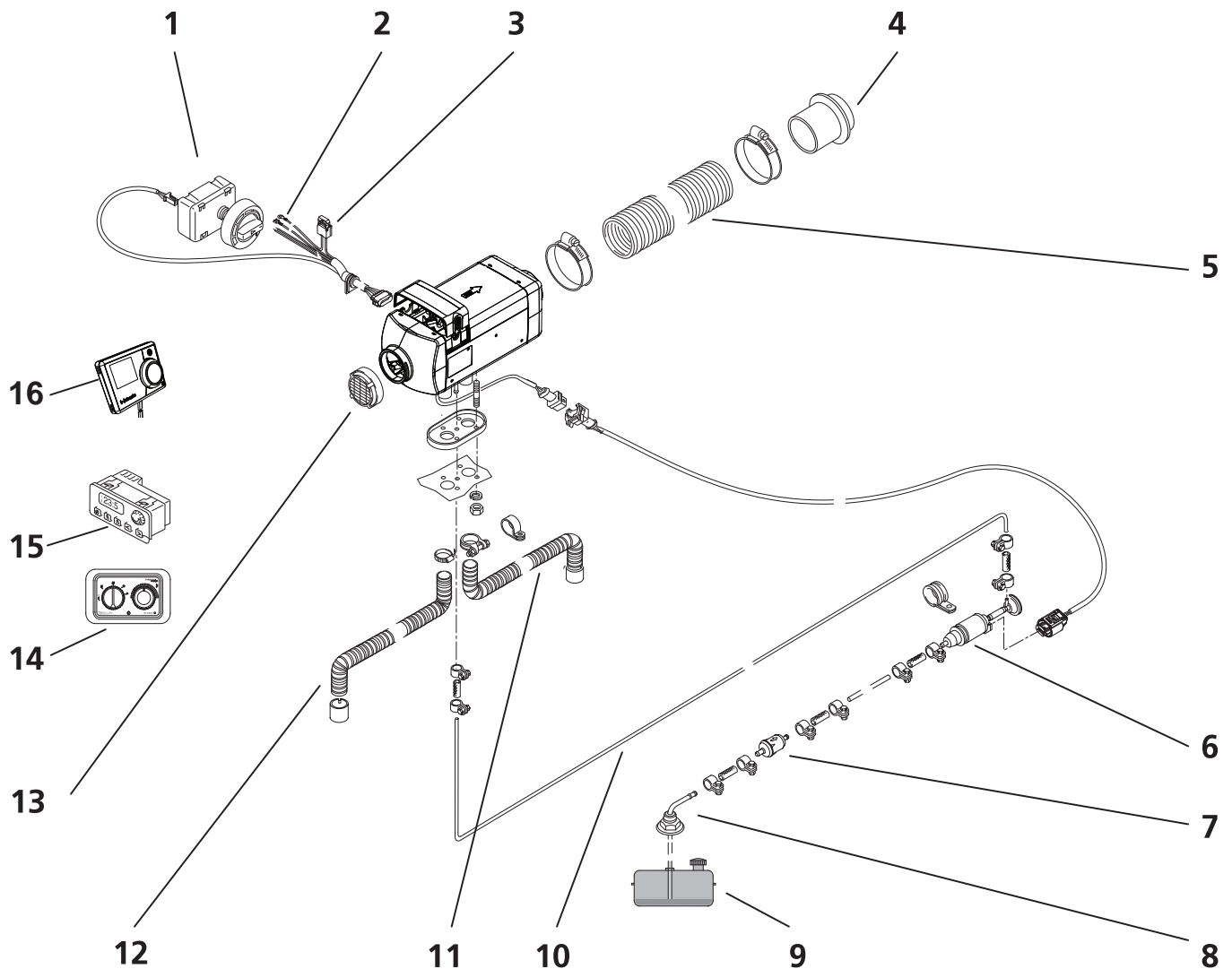

- 1 Rotary switch control element
- 2 Electrical vehicle interface
- 3 Heater fuse
- 4 Heating air outlet
- 5 Heating air outlet hose
- 6 Fuel pump
- 7 Fuel filter
- 8 Tank extracting device

- 9 Fuel tank
- 10 Fuel line
- 11 Exhaust pipe
- 12 Combustion air intake line
- 13 Heating air intake grille
- 14 Air Top Evo Multi Control (MC04) control element
- 15 Combination timer
- 16 MultiControl / SmartControl

Fig. 603 Component overview

## 6.3 Settings

### 6.3.1 Setting the CO<sub>2</sub> content

The CO<sub>2</sub> content in the exhaust gas is set using the adjustment knob on the control element. At a constant fan speed, the volume of fuel is controlled by changing the fuel pump cycle.

#### ATTENTION

The CO<sub>2</sub> measuring instruments must be calibrated.  
The heater must be switched off.

1. Connect the CO<sub>2</sub> line to the negative terminal.
2. Turn the adjustment knob on the control element to mid-position. The heater starts up and automatically assumes partial load mode.

#### NOTE

The operation indicator lamp flashes in the same way as for a control unit fault when the heater is ready to be adjusted.

#### Diesel heaters:

3. Set the CO<sub>2</sub> value by correspondingly turning the adjustment knob. Turning the adjustment knob anticlockwise reduces the CO<sub>2</sub> value while turning the knob clockwise will increase the value. The measured CO<sub>2</sub> content at partial load (1 kW) must be at  $6.6 \pm 0.5\%$ . After adjustment, the CO<sub>2</sub> content at full load should be  $10.3 \pm 0.5 \text{ vol.}\%$ .

#### Petrol heaters:

3. The CO<sub>2</sub> content should only be measured with the heater at operating temperature. For this purpose, the heater should be operated for at least 8 minutes. The CO<sub>2</sub> content is then set to  $7.3 \pm 0.5 \text{ vol.}\%$  at partial load (1 kW). After adjustment, the CO<sub>2</sub> content at full load should be  $10.3 \pm 0.5 \text{ vol.}\%$ .

#### Diesel and petrol heaters:

4. When the CO<sub>2</sub> value is in the permissible range, disconnect the CO<sub>2</sub> line from the negative terminal. This saves the setting.

#### NOTE

The heater will now run in normal mode again and can be switched off at the control element.  
The heater is set at the factory to match the fan motor.

### 6.3.2 CO<sub>2</sub> setting for reference heater

The reference heater is set at the factory to 10.3 vol.% CO<sub>2</sub> at a geodetic altitude of 0 m. To subsequently reset the heater, a CO<sub>2</sub> value must be set as a function of the geodetic altitude as shown in the diagram.

See Section 6.3.1.

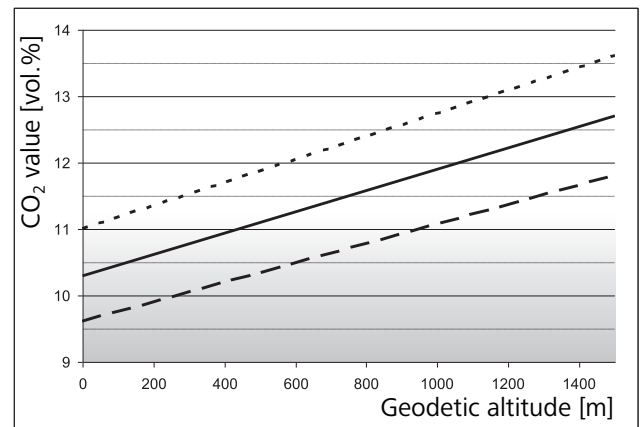

- CO<sub>2</sub> [vol.%]
- - - min. tolerance for operation [vol.%]
- . . . max. tolerance for operation [vol.%]

**6.4 Testing individual components****ATTENTION**

When carrying out function tests, always disconnect the connection between the control unit and the component to be tested.

**NOTE**

If this procedure is not able to detect the fault, the heater/ component must be sent in to the Webasto Warranty Department.

You will find the address for your Webasto dealer at <http://dealers.webasto.com>.

**NOTE**

Damage caused by soiling will not be recognised by Webasto!





**Legend to flowchart:**

- ① Replace component. Within the warranty period, send in the defective component (not the entire heater) to Webasto.
- ② Replace component and continue.
- ③ Replace heater. Within the warranty period, send in the defective heater to Webasto.
- ④ Continue.
- Ⓐ (or B, C), see flowchart.

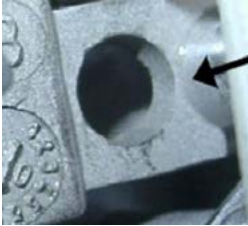

6.4.1 Component: burner

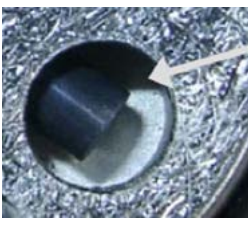
See Fig. 904, Item 5

	Procedure	Test and measuring equipment	Visualisation
<p>Burner</p> <p>Combustion chamber mechanically damaged?</p> <p>Yes <b>2</b></p> <p>No</p>	Visual inspection		
<p>Starting air hole open?</p> <p>No <b>1</b></p> <p>Yes</p>	Visual inspection		
<p>Pilot flame opening clear?</p> <p>No <b>1</b></p> <p>Yes</p>	Visual inspection		
<p>No blockages in fuel pipe?</p> <p>No <b>1</b></p> <p>Yes</p>	Blow through with mouth		
<p>Check function on heater test bench</p>	<p>Check function with reference heater. After 5 minutes of full load operation, set reference heater to nominal CO<sub>2</sub> value as shown in the graphic, install the burner to be tested in the reference heater and measure the CO<sub>2</sub> value after 5 minutes of full load operation</p>	<ul style="list-style-type: none"> <li>- Heater test bench</li> <li>- CO<sub>2</sub> measuring device</li> <li>- Webasto diagnostics adapter</li> <li>- PC (personal computer)</li> <li>- Reference heater</li> </ul>	
<p>Can CO<sub>2</sub> value be set within tolerance?</p> <p>No <b>1</b></p> <p>Yes <b>2</b></p>			

**6.4.2 Testing resistance of flame monitor (petrol heater only)**

See Abb. 904, Item 1

When testing with a digital multimeter, the flame monitor must show the following values:

**Cold test:**

Resistance at 25 °C: 2.6 - 3.4 ohms



Test current: < 5 mA

**Hot test:**

Resistance at 800 – 1000 °C: 12 - 15 ohms

Test current: < 5 mA

(ceramic rod red-hot over length of approx. 20 mm)

Flame monitor	Procedure	Test and measuring equipment	Visualisation
<p>Contacts detached?</p> <p>Yes <b>2</b></p> <p>No</p>	Visual inspection		
<p>Cables damaged?</p> <p>Yes <b>2</b></p> <p>No</p>	Visual inspection		
<p>Ceramic element broken?</p> <p>Yes <b>A</b></p> <p>No</p>	Visual inspection		
<p>Resistance outside 2.5 - 3.8 ohms?</p> <p>Yes <b>1</b></p> <p>No <b>2</b></p>	Resistance measurement	Digital multimeter	
<p><b>A</b></p> <p>Ceramic element broken due to force?</p> <p>No <b>1</b></p> <p>Yes <b>2</b></p>	Visual inspection		

**6.4.3 Component: glow plug**

See Abb. 904, Item 6

**NOTE**



The resistance must be measured with a ohmmeter suitable for low resistance.

Measuring the resistance with a simple digital multimeter is too inaccurate to determine the exact values. A new glow plug can be measured as a reference.

The glow plug should return the following values in the test:

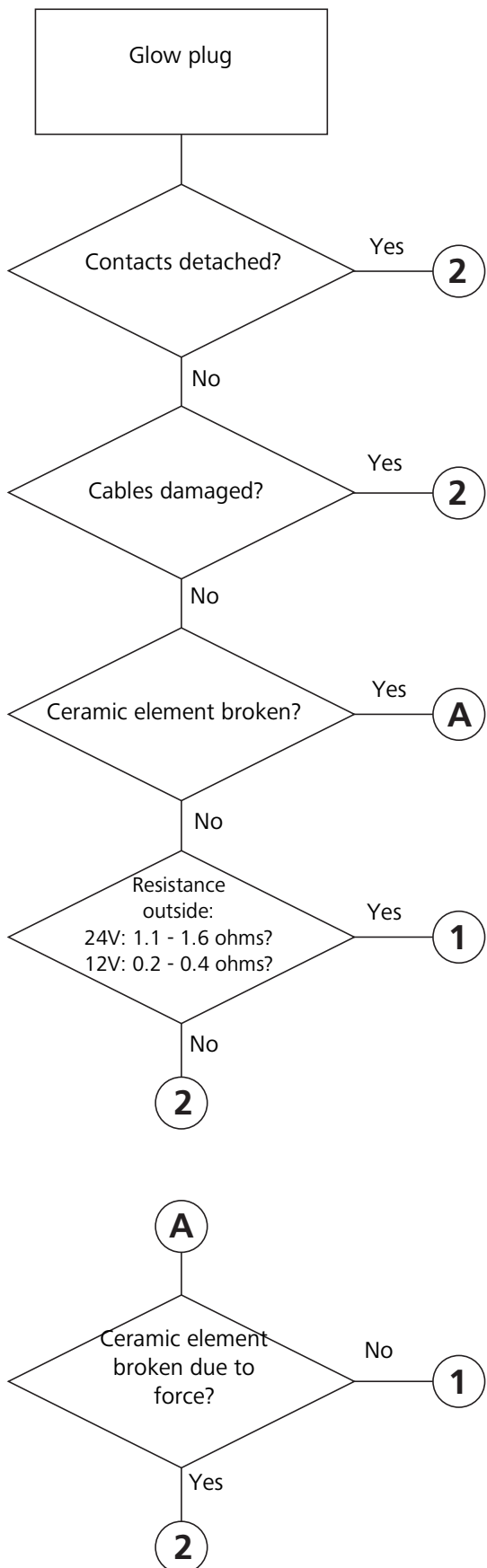
Glow plug:	12 V (red)	24 V (green)
Resistance		
at 25 °C:	0.263 - 0.323 ohms	1.125 - 1.375 ohms
Test current:	< 5 mA	< 5 mA

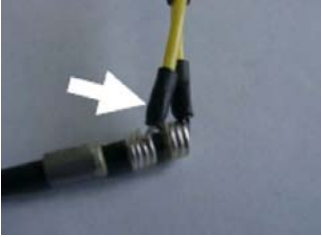

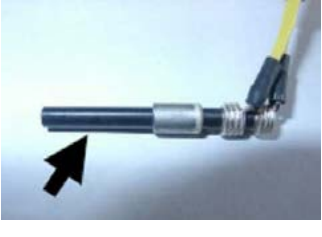
Procedure	Test and measuring equipment	Visualisation
Visual inspection		
Visual inspection		
Visual inspection		
Resistance measurement	Digital multimeter	

6.4.4 Component: drive unit

See Abb. 903, Item 5

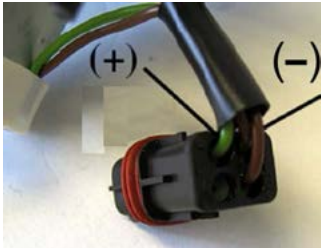
	Procedure	Test and measuring equipment	Visualisation
<p>Drive unit</p> <p>Externally damaged?</p> <p>Yes <b>1</b></p> <p>No</p>	<p>Visual inspection</p>		
<p>Components installed in heater =&gt; short to metal parts (heat exchanger, etc.)?</p> <p>Yes <b>1</b></p> <p>No</p>	<p>Continuity measurement</p>	<p>Digital multimeter</p>	
<p>Resistance &gt; 6 ohms?</p> <p>No <b>1</b></p> <p>Yes</p>			
<p>Start at 10 or 20 V?</p> <p>Yes <b>1</b></p> <p>No</p>	<p>Drive motor start-up</p>	<p>Voltage source</p>	
<p>Bearing noise?</p> <p>Yes <b>1</b></p> <p>No</p> <p><b>4</b></p>	<p>Subjective test</p>		<p><b>ATTENTION</b>                      Ensure correct polarity (+)/(-)                      (-) = brown                      (+) = red (12V), green (24V)</p>

**6.4.5 Component: overheating temperature sensor**

See Abb. 903, Item 8

When measuring the resistance with a digital multimeter, the overheating temperature sensor must return values as shown in the diagram (Fig. 601).

Overheating temperature sensor PT 2000 in temperature range 10 °C to 30 °C.

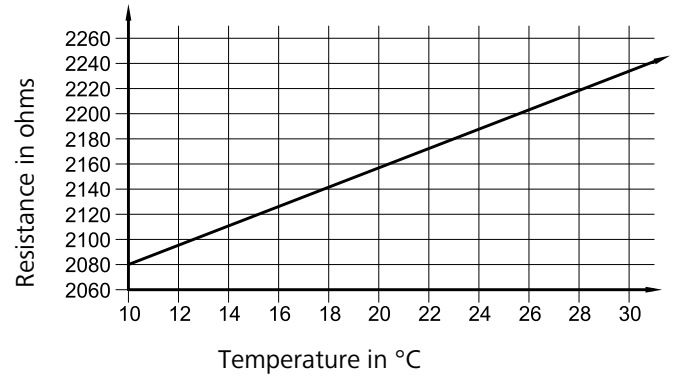
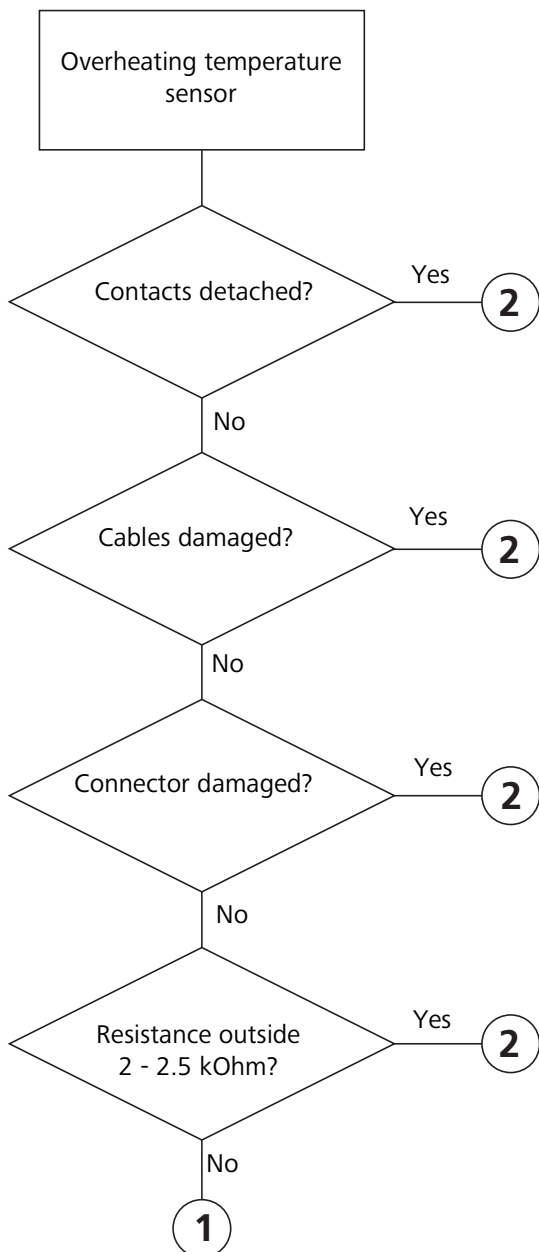





Fig. 601 Characteristic resistance values of an overheating temperature sensor



Procedure	Test and measuring equipment	Visualisation
Visual inspection		
Visual inspection		
Visual inspection		
Resistance measurement	Digital multimeter	

6.4.6 Component: control unit

See Abb. 701 and Abb. 903, Item 3

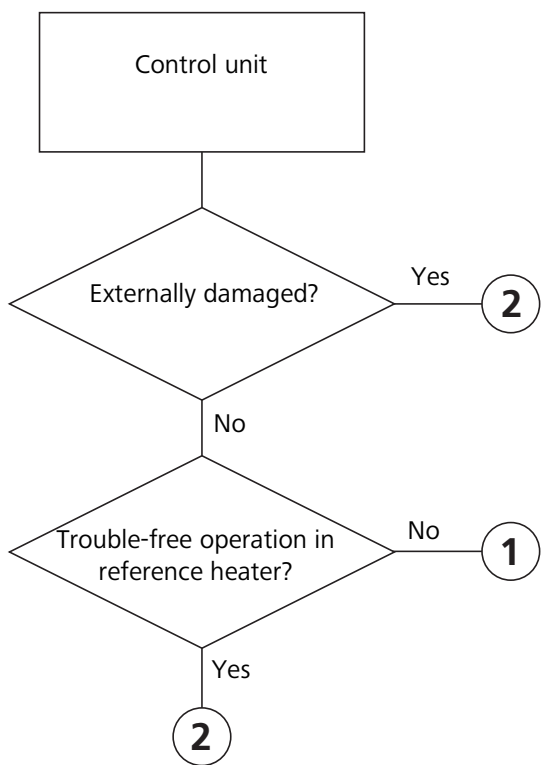

Procedure	Test and measuring equipment	Visualisation
<p>Visual inspection</p> <p>Check function with reference heater. install control unit to be tested in the reference heater and carry out function test</p>	<ul style="list-style-type: none"> <li>- Heater test bench</li> <li>- PC (personal computer)</li> <li>- Webasto diagnostics adapter</li> <li>- Reference heater</li> </ul>	



6.4.7 Component: heater

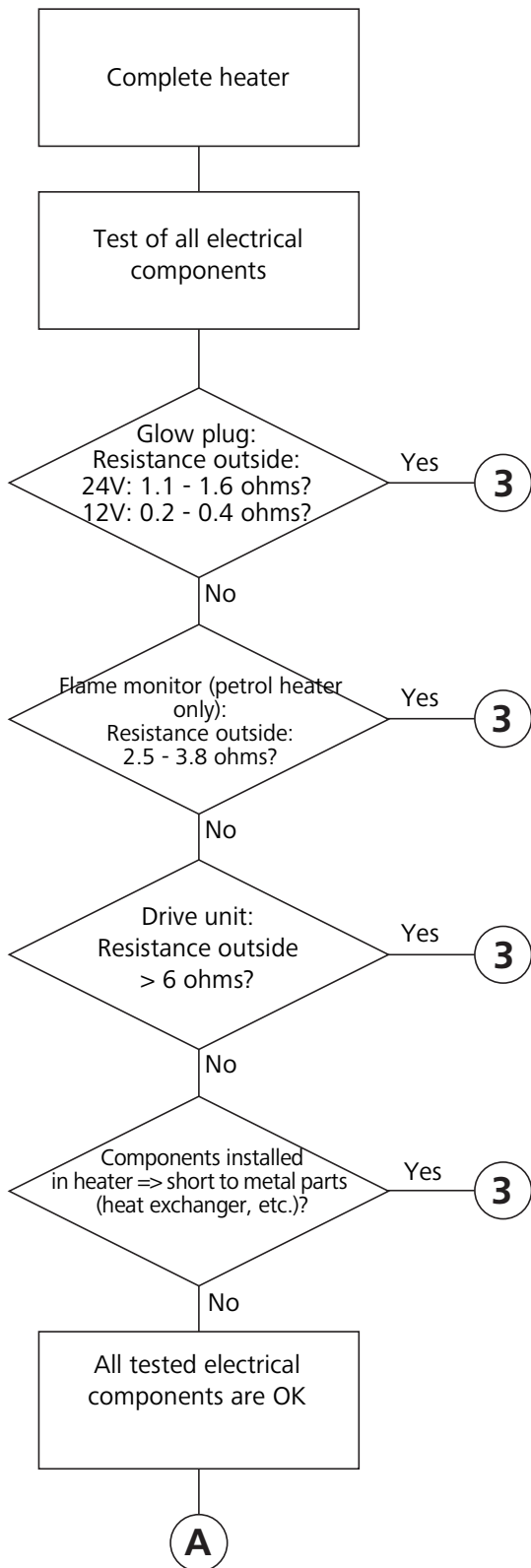

Description	Procedure	Test and measuring equipment
Remove upper casing from heater, unplug component connector from control unit pcb, cable colour of individual components: glow plug (yellow). flame monitor (brown), drive unit (negative and ground: brown, positive: red/green), overheating protection (blue), fuel pump (black)		
Replace component and continue	Resistance measurement	Digital multimeter
Replace component and continue	Resistance measurement	Digital multimeter
Replace component and continue	Resistance measurement	Digital multimeter
Replace component and continue	Continuity measurement	Digital multimeter

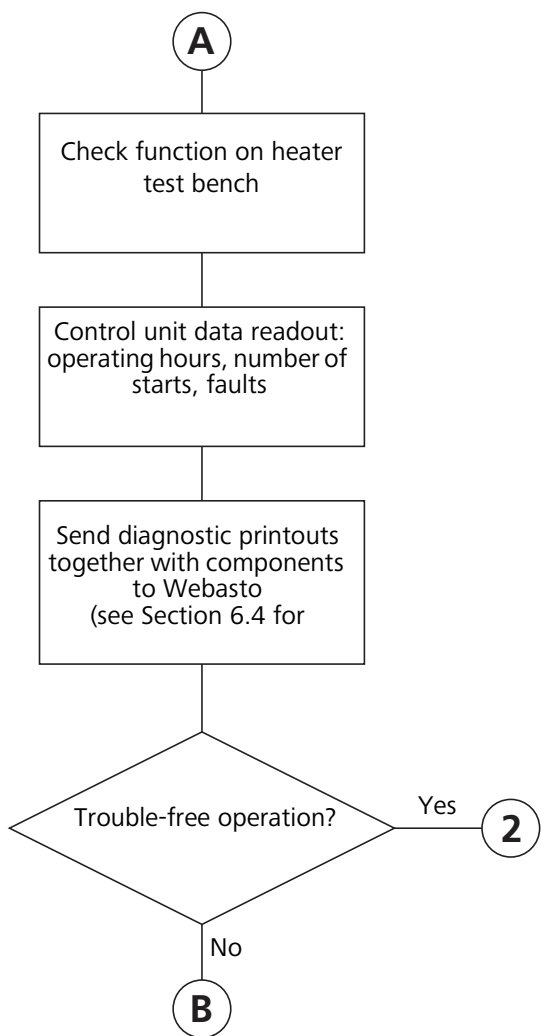

Description	Procedure	Test and measuring equipment
	Function check	<ul style="list-style-type: none"> <li>- Heater test bench</li> <li>- PC (personal computer)</li> <li>- Webasto diagnostics adapter</li> </ul>

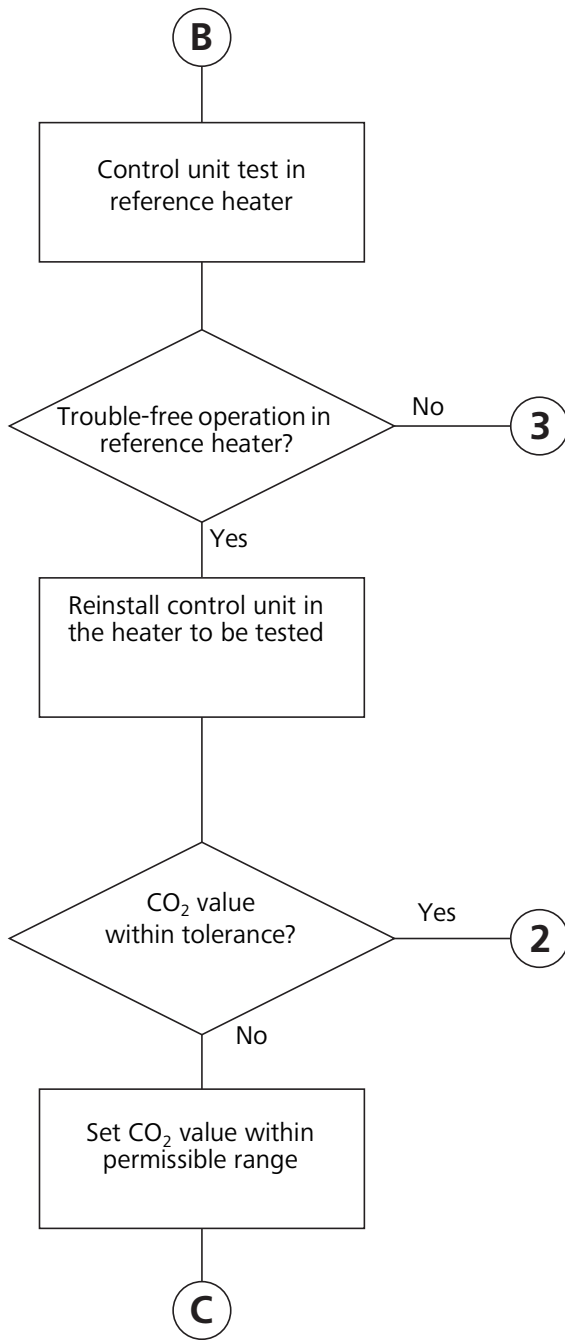

Description	Procedure	Test and measuring equipment
	Function check	<ul style="list-style-type: none"> <li>- Heater test bench</li> <li>- CO<sub>2</sub> measuring device</li> <li>- PC (personal computer)</li> <li>- Webasto diagnostics adapter</li> <li>- Reference heater</li> </ul>
	CO <sub>2</sub> measurement	

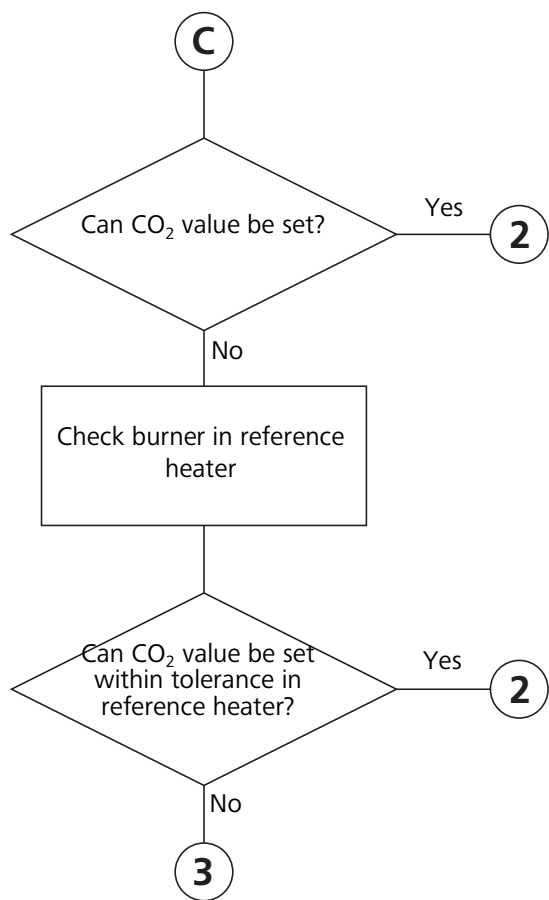

Description	Procedure	Test and measuring equipment
<p>Check function with reference heater. After 5 minutes of operation, set reference heater to nominal CO<sub>2</sub> value as shown in the graphic, install the burner to be tested in the reference heater and measure the CO<sub>2</sub> value after 5 minutes of operation</p>	<p>Function check</p> <p>CO<sub>2</sub> measurement</p>	<ul style="list-style-type: none"> <li>- Heater test bench</li> <li>- CO<sub>2</sub> measuring device</li> <li>- PC (personal computer)</li> <li>- Webasto diagnostics adapter</li> <li>- Reference heater</li> </ul>

Page for notes

## 7 Wiring diagrams

### 7.1 General information

The Air Top 2000 STC heater can be operated with the control element (rotary switch or switch), combination timer or MultiControl/SmartControl.

The wiring diagrams (Fig. 702 to Fig. 705) show the possible connections for 12 or 24 volt systems with:

- MultiControl element
- MultiControl element and battery disconnecter
- ADR operation with switch
- ADR operation with SmartControl

Fig. 701 shows plug assignments at control unit.

See 7.3 for wiring diagram legends.

See 7.4 for connector X6 pin assignments

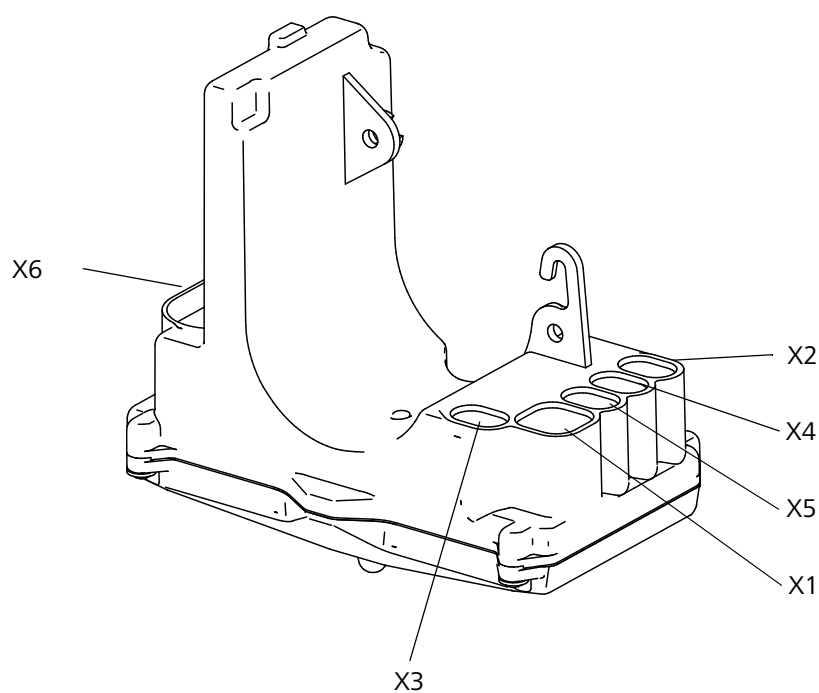

- X1 = Drive motor connection
- X2 = Glow plug connection
- X3 = Overheating temperature sensor connection
- X4 = Fuel pump connection
- X5 = Flame monitor connection (petrol heater only)
- X6 = Wiring harness connection

Fig. 701 Connector assignments

7.2 System wiring diagrams

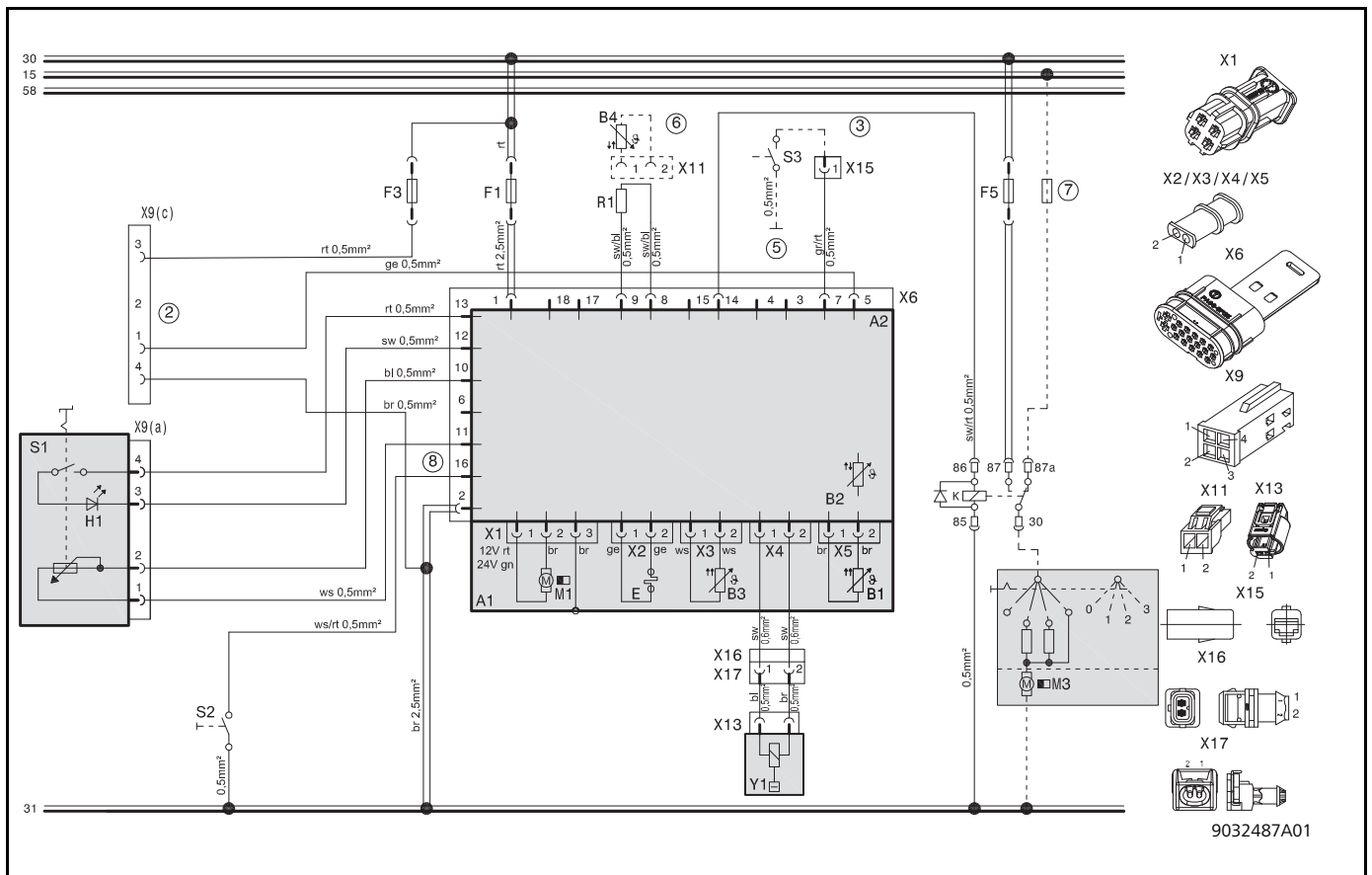

Fig. 702 System wiring diagram Air Top 2000 STC, 12 V/24 V with rotary switch

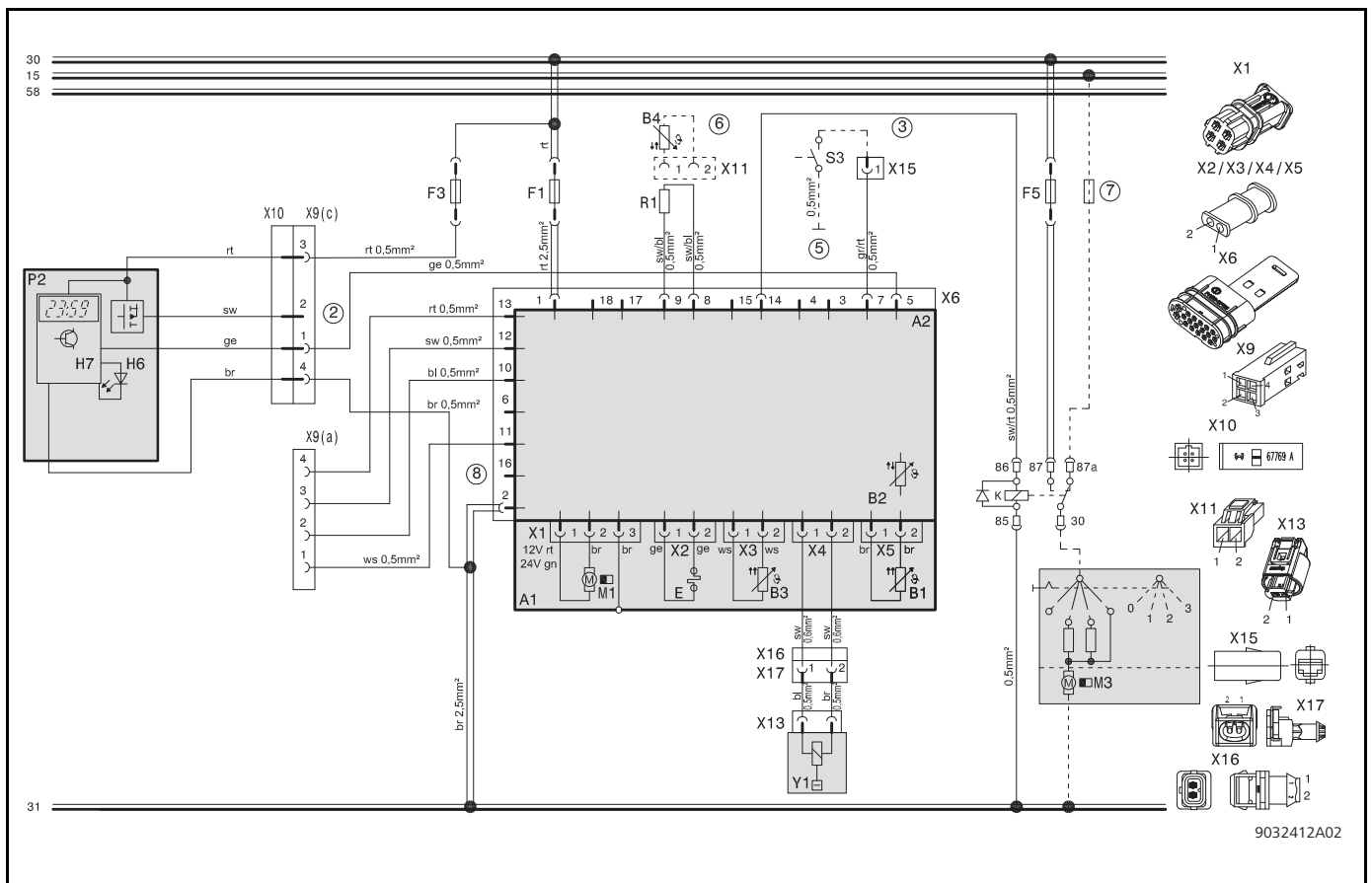

Fig. 703 Systems wiring diagram Air Top 2000 STC, 12 V/24 V with MultiControl

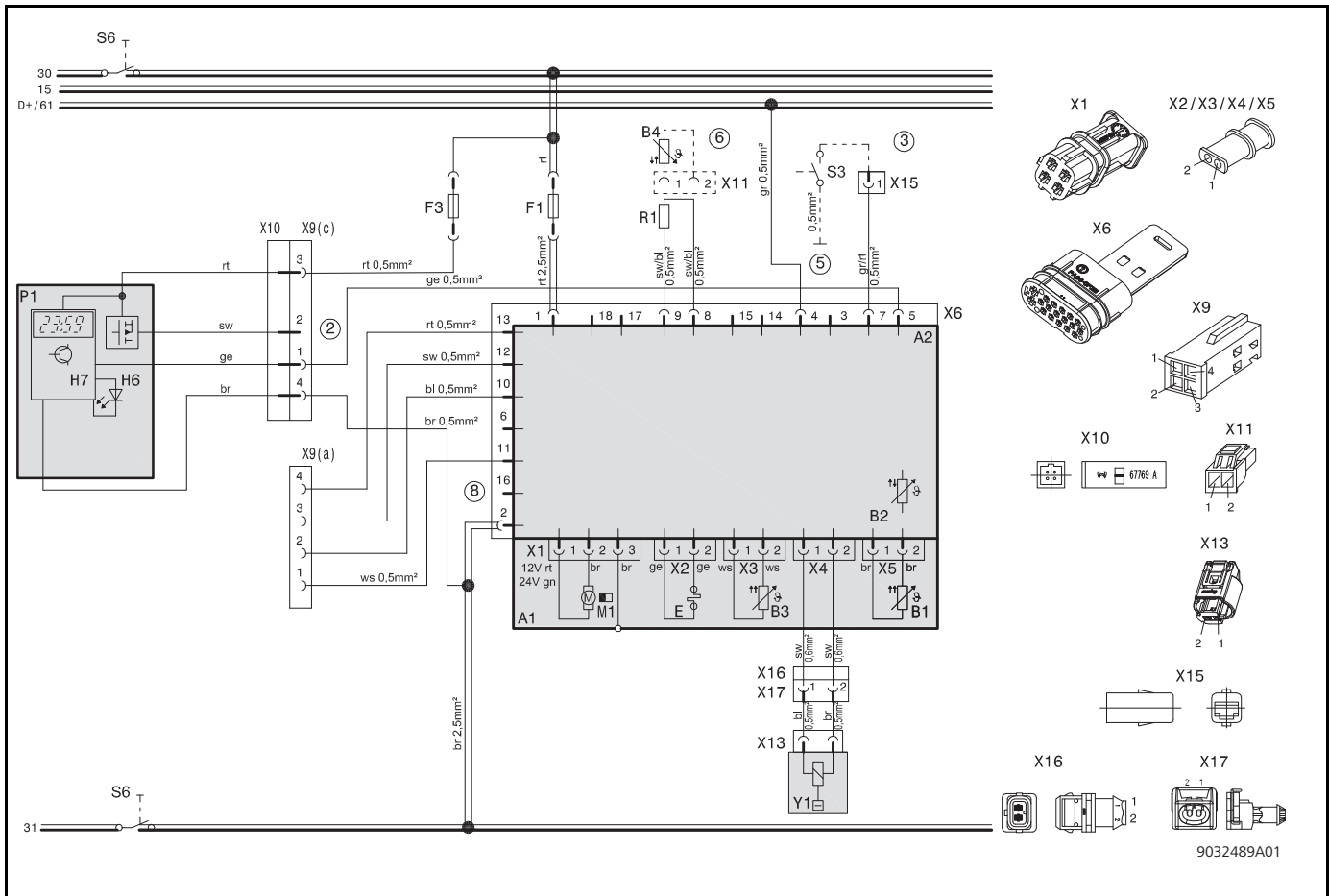

Fig. 704 System wiring diagram Air Top 2000 STC D, 12 V/24 V ADR operation with SmartControl

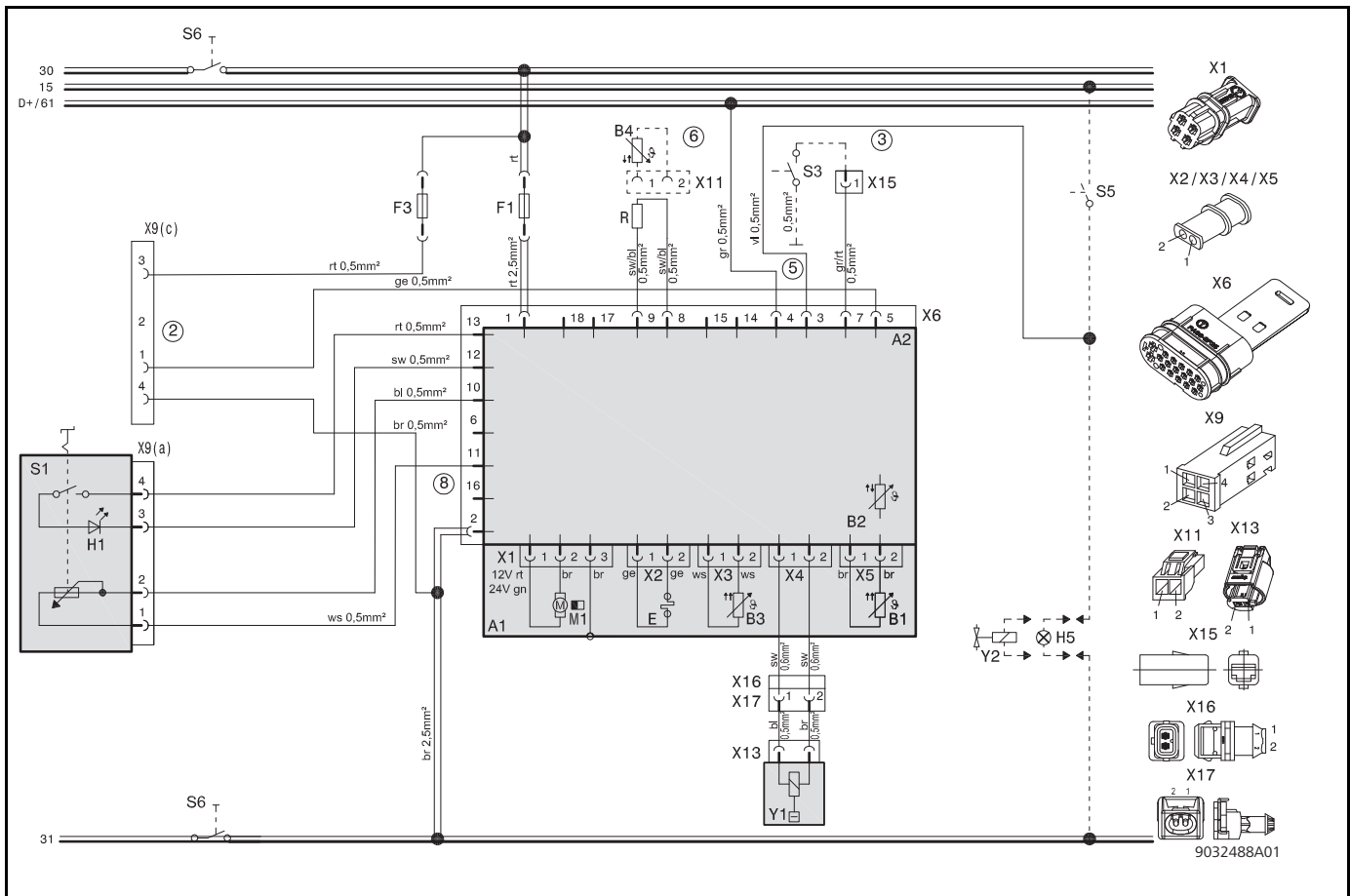

Fig. 705 System wiring diagram Air Top 2000 STC D, 12 V/24 V ADR operation with rotary switch



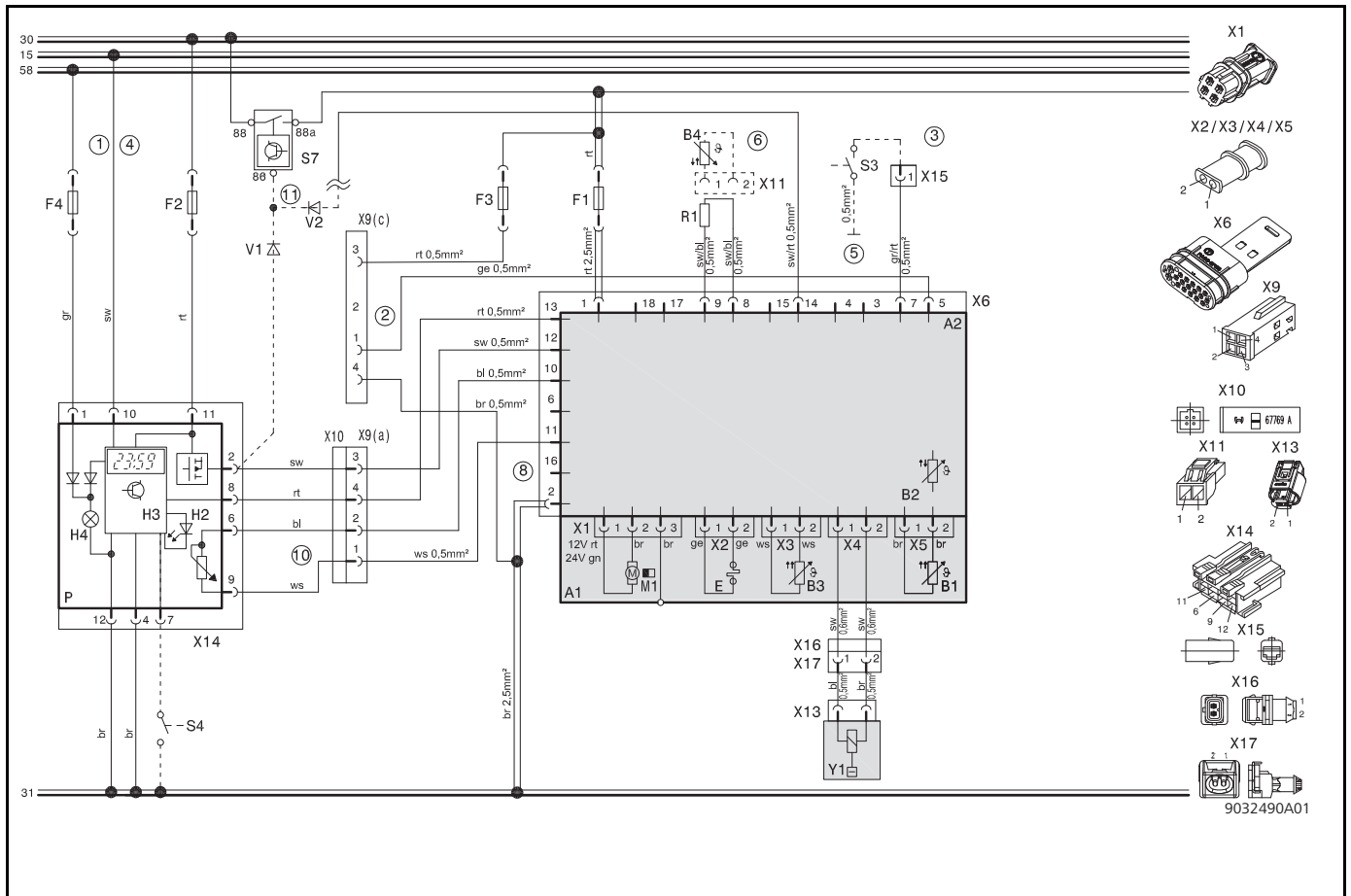

Fig. 706 System wiring diagram Air Top 2000 STC, 12 V/24 V with combination timer

### 7.3 Legends to system wiring diagrams

Cable cross-sections		
	< 7.5 m	7.5 - 15 m
	0.75 mm <sup>2</sup>	1.0 mm <sup>2</sup>
	1.0 mm <sup>2</sup>	1.5 mm <sup>2</sup>
	1.5 mm <sup>2</sup>	2.5 mm <sup>2</sup>
	2.5 mm <sup>2</sup>	4.0 mm <sup>2</sup>
	4.0 mm <sup>2</sup>	6.0 mm <sup>2</sup>

Cable colours	
bl	blue
br	brown
ge	yellow
gn	green
gr	grey
or	orange
rt	red
sw	black
vi	violet
ws	white

Item	Description	Remarks
A1	Heater	Air Top 2000 STC
A2	Control unit	Control unit
A3	UniBox	-
B1	Flame monitor	Only for petrol heaters
B2	Temperature sensor	internal
B3	Overheating temperature sensor	Overheating protection
B4	Room temperature sensor	external
E	Glow plug	-

Item	Description	Remarks
F1	Fuse 24 V, 15 A 12 V, 15A (max. 20 A)	Blade fuse DIN 72581-3
F2	Fuse 1A	Not included in wiring harness
F3	Fuse 1A	Blade fuse DIN 72581-3
F4	Fuse 1A	Not included in wiring harness
F5	Fuse	Value [in A] to be selected corresponding to cable cross-section; not included in wiring harness
H1	LED green (in Item S1)	ON indicator, fault code indicator

Item	Description	Remarks
H2	LED red (in Item P)	Lighting:Quick Heating button, Ready indicator, ON indicator
H3	Heating symbol on display (in Item P)	ON indicator, ready indicator
H4	Bulb/LED (in Item P)	Display and button lighting
H5	Bulb/LED	ON indicator, pumping device (max. 500 mA)
H6	LED (green, blue, white, red)	Operation indicator, Ready indicator, ON indicator, fault list
H7	Symbol on display	-
K	Relay with free-wheeling diode	Vehicle blower (max. 500 mA)
M1	Drive motor	Heating air and combustion air fan
M3	Motor	Vehicle blower
P	Combination timer 1531	Control element
P1	SmartControl	(W-bus)
P2	MultiControl or SmartControl	(W-bus)
R1	Resistor	Only for internal temperature sensor
S1	Control element (rotary switch)	ON/OFF switch and temperature setpoint sensor
S2	Switch	Ventilation
S3	Switch	CO <sub>2</sub> setting
S4	Push button	External Quick Heating button
S5	Switch	Auxiliary drive / pumping device
S6	Switch, 1 or 2-pin	Disconnecter
S7	Battery disconnecter	Electronically controlled disconnecter (max. 500 mA)
V1-V2	Blocking diode	Min. 500 mA
X1-X6	Plug connection	To Item A2
X9	Plug connection	-
X9 (a)	Plug connection	To Item S1
X9 (c)	Plug connection	W-bus, connection SmartControl/MultiControl, Telestart (12 V only), ThermoCall or diagnosis
X10	Plug connection	To Item P1 or P2
X11	Plug connection (optional)	To Item B4
X13	Plug connection	To Item Y1
X14	Plug connection	To Item P
X15	Plug connection (optional)	To Item S3
X16	Plug connection	Wiring harness connection DP42
X17	Plug connection	Wiring harness connection DP42
Y1	Fuel pump	DP42
Y2	Solenoid valve / pump	Auxiliary drive / pumping device

Item	Remarks
①	Positive from terminal 15/75 to connection 10: Continuous heating mode is possible in connection with quick heating function provided the ignition is switched on.
②	All heater versions: connection W-bus diagnosis, SmartControl/MultiControl, ThermoCall or Telestart (12V only).
③	CO <sub>2</sub> setting (see workshop manual)
④	Connection to terminal 30: Continuous heating mode is possible with ignition switched off.
⑤	Grey and violet wires required for ADR function. Non-ADR vehicles: Insulate and tie back ends of wires.
⑥	External room temperature sensor (optional)
⑦	Fuse in vehicle.
⑧	Pin 16 "Ventilate" (only for operation with control elements without W-bus)
⑨	The connection is not permitted for use of the combination timer 1531 in ADR vehicles.
⑩	Wiring harness adapter (optional)
⑪	Switching capacity 250 mA

#### 7.4 Pin assignments plug connection X6, 18-pin

Pin No.	Remarks
1	Power supply + (terminal 30)
2	Power supply – (terminal 31)
3	Auxiliary drive
4	Terminal D+
5	W-bus (Webasto Thermo Test Diagnosis connection)
6	K-bus
7	CO <sub>2</sub> setting
8	external temperature sensor +
9	external temperature sensor -
10	Setpoint sensor +
11	Setpoint sensor -
12	Input, switch-on signal (ON/OFF)
13	Power supply, control element / error code output
14	Output, vehicle fan relay/output, battery disconnecter afterrunning signal
15	Output, battery disconnecter afterrunning signal/output, vehicle fan relay
16	Input, Ventilate (only for operation with control elements without W-bus)
17	Not used
18	Not used

Page for notes

## 8 Servicing

### 8.1 General information

This section describes the servicing jobs that can be carried out on the heater when installed.

### 8.2 Working on the heater

Always disconnect the main power cable from the vehicle battery before carrying out any work on the heater. The main battery power must not be disconnected whilst the heater is operating or afterrunning due the risk of the heater overheating and consequently the overheating safeguard tripping. If extensive repair work is to be carried out on the heater, it may be a good idea to remove it completely.

Refer to the relevant installation instructions and the recommended vehicle-specific installation position for repairs that require the heater to be installed in a different position.

### 8.3 Working on the vehicle

#### ATTENTION

On no account must a temperature of 85 °C be exceeded in the vicinity of the heater (e.g. vehicle paintwork).

### 8.4 Heater test run

#### CAUTION

Even if you use the timer, the heater must not be operated in enclosed spaces such as garages and workshops without an emissions extraction system.

#### ATTENTION

The heater must not be operated without the control unit cover as this will cause the heater to overheat.

### 8.5 Servicing

#### NOTE

The heater should be operated for approx. 10 minutes every 4 weeks to prevent mechanical parts seizing.

The heater requires no maintenance. It should however be checked at regular intervals, at the start of the heating period at the latest (when the heater will be used more frequently due to colder weather conditions) by Webasto-trained technical personnel.

The following servicing jobs should be carried out to maintain the functional reliability of the heater:

- Checking heating air inlet and outlet for dirt and foreign objects. (Dirty or blocked heating air lines can cause overheating.)
- Cleaning heater exterior (make sure no water gets in).
- Checking electrical connections for contact corrosion and ensuring they are secure.
- Checking exhaust and combustion air intake lines for damage and ensuring they are clear.
- Replacing fuel filter, if fitted.
- Checking fuel line and filter for leaks.

### 8.6 Visual inspection and installation requirements

#### 8.6.1 Heating air system

#### ATTENTION

Due to the high pressure in the vehicle system, it is not permitted to integrate the heater into the vehicle's air circulation system.

On the inside of the control unit there is a room temperature sensor which operates the heater in the heating output range corresponding to the intake air temperature and setting of the control element. The heating capacity is set such that, after the selected interior temperature has been reached quickly, the output is maintained at the preselected value. Alternatively, the heaters can be operated with an external room temperature sensor (see 9.1.2).

#### NOTE

Only materials that can permanently withstand temperatures of at least 130 °C are to be used for the heating air duct.

Maximum pressure drop between the intake and pressure side of the heating air line 1.5 hPa (corresponds to 1.5 mbar or 15 mm water column).

The heating air outlet temperature control may reduce the heating capacity if this value is exceeded.

The inside diameter of the main section of the heating air line should be 60 mm.

The permissible pressure drop will be exceeded faster if smaller diameter lines are used.

The heating air hose is to be secured at the connection points.

The heater can be used in recirculated air mode if there is a grille on the heating air inlet and outlet side. Avoid short-circuiting the heating air flow.

**ATTENTION**

In vehicles used to transport persons, the air outlet opening is to be arranged such that it is at least 20 cm away from any parts of the body.

When switched on, the heater automatically checks the internal rise in temperature. If the rise in temperature is above the specified limit, the start-up procedure is cancelled and an error message (see "Troubleshooting" on page 501) displayed. The resistance to flow in the connected heating air system must be reduced to ensure stable heater operation.

If a filter is used for the heating air, it must have the following properties:

- The flow of air must not carry any flammable and/or harmful fibres or particles into the heater and the vehicle interior.
- The filter material must be able to withstand temperatures of at least 60 °C
- The filter material must be resistant to all substances that may be drawn in with the heating air. (e.g. moisture, salt, fuel vapours, etc.)
- The resistance offered by the filter must be taken into account when laying out the heating air circuit.

**8.6.2 Fuel supply**

**CAUTION**

**Risk of fire by fuel escaping from leaking plastic fuel tank.**

Skin burns

- Do not drill into a plastic fuel tank.
- When retrofitting the fuel take-off system on a plastic tank: Install the Webasto tank extracting device only on the vehicle's fuel delivery unit.

**NOTE**

Refer to the Air Top 2000 STC installation instructions for requirements relating the fuel system.

**8.6.2.1 Fuel take-off, general**

The fuel is taken from the vehicle's fuel tank or from a separate fuel tank. Make sure that the installation location meets the following requirements:

- Fuel can be taken directly from the fuel tank.
- Fuel must be taken from the vehicle's fuel tank or a separate fuel tank.
- Only use the genuine Webasto tank extracting device.
- Make sure that the swirl pot is not completely emptied during operation.

See accessories catalogue for suitable tank extracting device.

**8.6.2.2 Permissible fuel pressure fuel line lengths.**

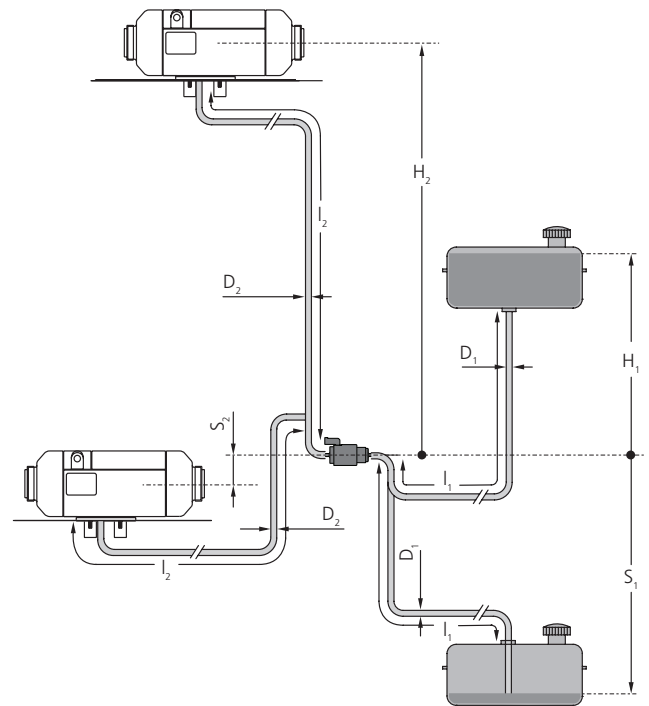

Fig. 801 Fuel line lengths, inside diameter and height differences (fuel tank, heater) to fuel pump

**To Fig. 801:**

Parameter	Value	
	Petrol	Diesel
Inside diameter of fuel line D <sub>1</sub> , D <sub>2</sub> [mm]	max. 2	
Length of intake pipe l <sub>1</sub> [m]	max. 5	
Length of pressure pipe l <sub>2</sub> [m]	max. 10	
Length of intake pipe l <sub>1</sub> + length of pressure pipe l <sub>2</sub> [m]	max. 12	
Distance from tank filling level - fuel pump (Tank <b>above</b> fuel pump [m]) H <sub>1</sub> [m]	max. 2	
Distance from tank filling level - fuel pump (Tank <b>below</b> fuel pump [m]) S <sub>1</sub> [m]	max. 1	max. 1.3
Height difference between heater and fuel pump (Heater <b>above</b> fuel pump) H <sub>2</sub> [m]	max. 3	
Height difference between heater and fuel pump (Heater <b>below</b> fuel pump) S <sub>2</sub> [m]	max. 0*	max. 1

**NOTE**

\* Petrol heater: only pressure pipe with rising gradient permitted

**Maximum permissible fuel pressure**

Distance between fuel level and fuel pump (tank above fuel pump [m]) H <sub>1</sub>	Maximum permissible fuel pressure at take-off point, p <sub>1</sub> [bar]	
	Petrol	Diesel
H <sub>1</sub> = 0	-0.1 ≤ p <sub>1</sub> ≤ +0.3	-0.1 ≤ p <sub>1</sub> ≤ +0.5
0 < H <sub>1</sub> ≤ 1	-0.1 ≤ p <sub>1</sub> ≤ +0.2	-0.1 ≤ p <sub>1</sub> ≤ +0.4
1 < H <sub>1</sub> ≤ 2	-0.1 ≤ p <sub>1</sub> ≤ +0.1	-0.1 ≤ p <sub>1</sub> ≤ +0.3

Distance between fuel level and fuel pump (tank below fuel pump [m]) S <sub>1</sub>	Maximum permissible fuel pressure at take-off point, p <sub>1</sub> [bar]	
	Petrol	Diesel
S <sub>1</sub> = 0	-0.1 ≤ p <sub>1</sub> ≤ +0.3	-0.1 ≤ p <sub>1</sub> ≤ +0.5
-0.5 < S <sub>1</sub> < 0	-0.06 ≤ p <sub>1</sub> ≤ +0.3	
-1.0 < S <sub>1</sub> ≤ -0.5	-0.02 ≤ p <sub>1</sub> ≤ +0.3	
-1.3 < S <sub>1</sub> ≤ -1.0	-	

8.6.2.3 Fuel take-off via tank drain plug (from plastic or metal fuel tank)

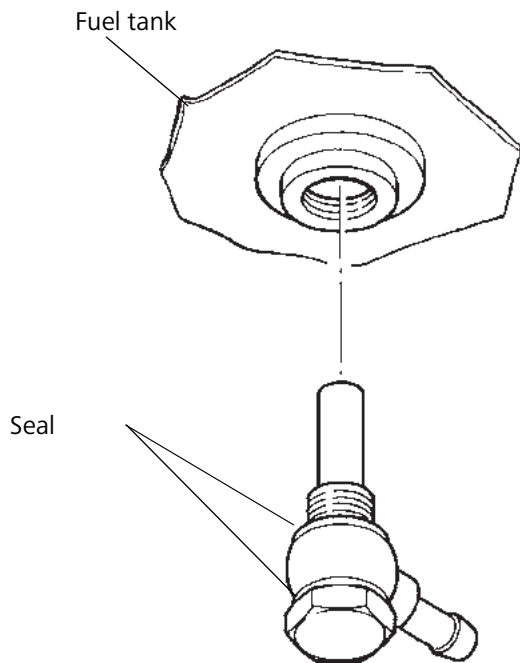

Fig. 802 Fuel take-off via tank drain plug (plastic or metal fuel tank)

8.6.2.4 Webasto tank extracting device for plastic fuel tank

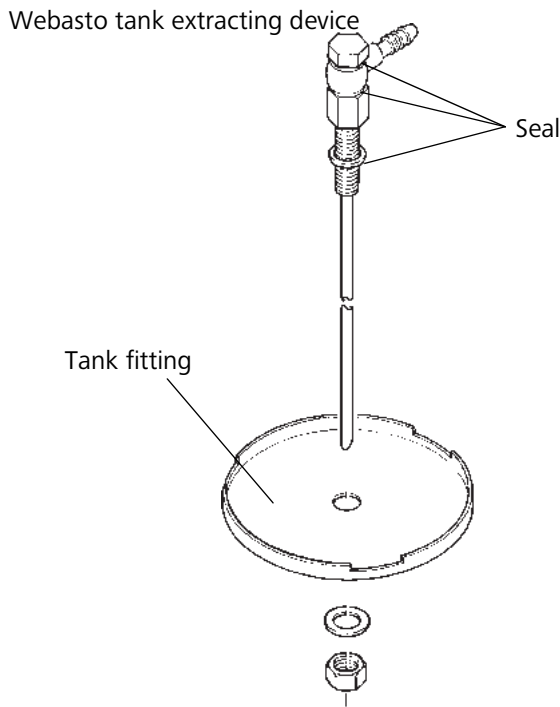

Fig. 803 Webasto tank extracting device (plastic fuel tank)

**NOTE**

Use the Webasto tank extracting device for plastic fuel tanks only for fuel tanks made of plastic.

8.6.2.5 Webasto tank extracting device for metal tank

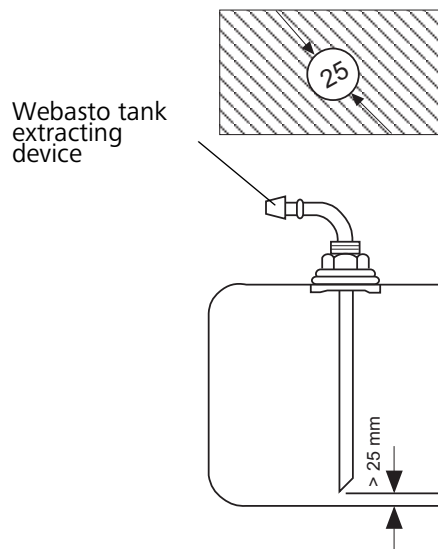

Fig. 804 Webasto tank extracting device (metal fuel tank)

**NOTE**

Use the Webasto tank extracting device for metal fuel tanks only for non-pressurised fuel tanks made of metal.

A hole is only permitted in the top of the fuel tank. Hole diameter 25 mm.

See accessories catalogue for suitable tank extracting device for metal fuel tanks.

Separate fuel extraction has no influence on the pressure.

8.6.2.6 Fuel lines

Only steel or plastic fuel lines made of plasticised, light and temperature-resistant PA11 or PA12 (e.g. Mecanyl-RWTL) in accordance with DIN 73378 may be used as the fuel pipes. Since it is not usually possible to ensure that the line is installed with a gentle slope, the internal diameter must not exceed a specified dimension. The specified diameters make sure that no disruptive bubbles form.

Avoid routing lines downward from the fuel pump to the heater.

Unsupported fuel lines must be secured to prevent them sagging. The lines must be installed in such a way that they are protected from stone chip damage and the **effects of temperature** (exhaust line).

The fuel lines must be secured with hose clips at the connection points to prevent them slipping off.

8.6.2.7 Connecting 2 fuel lines with a hose

Fig. 805 shows the correct connection of fuel lines with a hose.

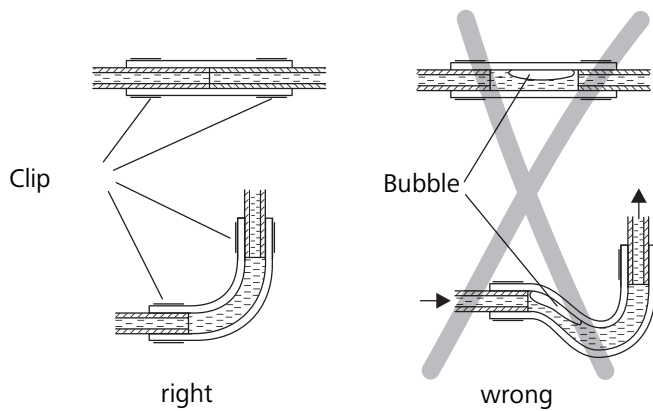

Fig. 805 Pipe/hose connections

8.6.3 Fuel pump

The fuel pump is a combined delivery, metering and a shut-off system and is subject to certain installation criteria (Fig. 806, Fig. 807).

8.6.3.1 Installation location

It is advisable to install the fuel pump in a cool location. The ambient temperature must not exceed +20 °C at any time during operation.

The fuel pump and fuel lines must not be installed within the range of radiated heat from hot vehicle parts. If necessary, a heat shield should be fitted.

8.6.3.2 Installation and attachment

Petrol

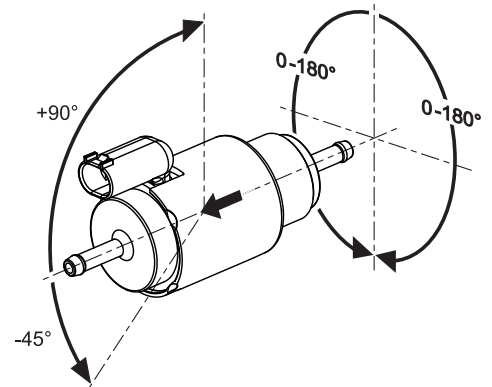

Fig. 806 DP42 fuel pump (installation position, petrol)

Diesel

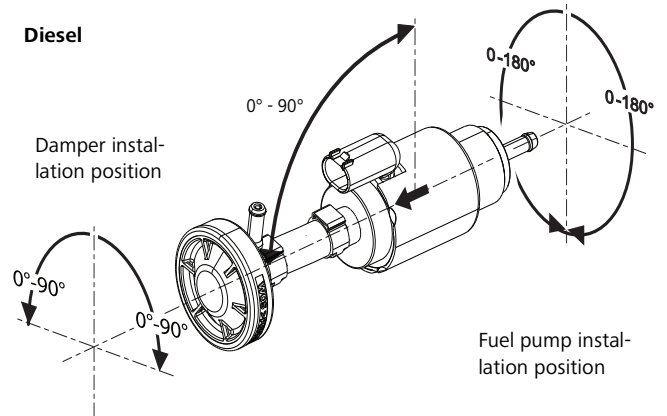

Fig. 807 DP42 fuel pump, installation position, diesel

The installation position is limited as shown in Fig. 806 and Fig. 807 to ensure effective automatic bleeding.

**Diesel only:**

Install the fuel pump with diaphragm damper between 0° and 90° to the horizontal.

The fuel pump with diaphragm damper must be secured with a vibration-damping mounting.

Due to the risk of corrosion only genuine Webasto parts must be used for the plug connection between the fuel pump and fuel pump wiring harness.

### 8.6.4 Fuel filter

Installation location of fuel filter: between fuel tank and fuel pump.

Only a Webasto filter, Ident. No. 487 171, is to be fitted if poor-quality fuel is used. Install vertically if possible, maximum deviation not exceeding 90° (ensure correct direction of flow).

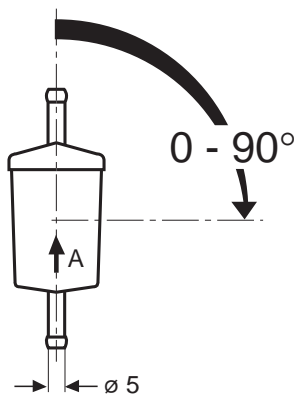

Fig. 808 Fuel filter

### 8.6.5 Combustion air supply

Under no circumstances may the combustion air be taken from areas occupied by persons. The combustion air intake opening must not face in the direction of travel. It must be arranged in such a way that it cannot become clogged with dirt.

#### NOTE

For petrol heaters, the combustion air must be taken, using a combustion air intake line, from a position that is as cool as possible and protected from splash water.

If the heater is enclosed in a casing, the combustion air must be drawn in from the outside and the exhaust gas fed to the outside. The holes must be made such as to ensure that exhaust gas cannot get into the vehicle interior.

A fuel filter can be installed if dirty combustion air is expected (only Air Top 2000 STC D). A combustion air intake silencer must be used for a combustion air intake line < 0.6 m.

### 8.6.6 Exhaust line

Rigid pipes made from unalloyed or alloyed steel with a minimum wall thickness of 1.0 mm or flexible piping made of alloyed steel must be used for the exhaust pipe. The exhaust line must be secured to the heater and exhaust silencer with the pipe clip Ident. No. 20965A.

### 8.6.7 Exhaust silencer

The exhaust silencer (Fig. 809) should preferably be installed close to the heater. Any direction of flow.

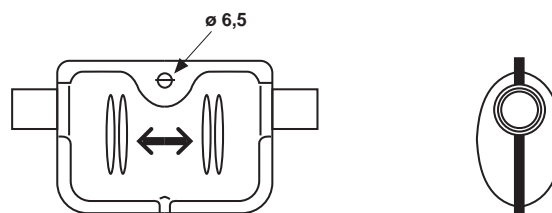

Fig. 809 Exhaust silencer

The heater can also be operated without an exhaust silencer.



**8.6.8 Combustion air intake and exhaust pipes**

To avoid damaging the fuel pump cable, exhaust pipe must not be used to extend the combustion air supply line.

Length of combustion air intake line and exhaust pipes:

With exhaust silencer: max. 2.0 m

Without exhaust silencer: max. 5.0 m

Both pipes must be installed routing downwards from the heater. If this is not possible, a 4 mm  $\varnothing$  condensation drain hole must be made at the lowest point or a connecting element with condensed-water drain must be used.

Inside diameter of lines:

Combustion air intake line: 22 mm

Exhaust pipe: 22 mm

**NOTE**

Exhaust pipes longer than 2 m must be insulated (to prevent the temperature dropping below the dew point).

Smallest bending radius: 50 mm

Attachment no further than 150 mm from the end of the exhaust pipe is required to achieve the required angle of  $90^\circ \pm 10^\circ$ .

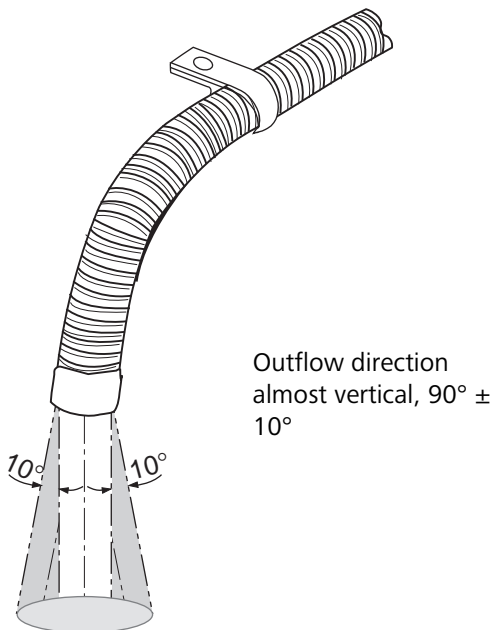

Fig. 810 End of exhaust pipe, installation position

**CAUTION**

Risk of fire if the exhaust pipe ends other than shown in Fig. 810.

Sum of all bends:

Combustion air intake line: max. 270°

Exhaust pipe: max. 270°

**8.6.9 Electrical Connections**

**8.6.9.1 Heater and control element connection**

Electrical connection is made as shown in the wiring diagram (see Section 7).

To connect the wiring harness, remove the cover (see 9.2.1.1) on the heater and connect the wiring harness plug to the control unit.

To prevent the heating air escaping (heater overheating), reattach the cover prior to initial operation.

The wiring harness can be fed out of the heater either on the left side or right side.

**8.6.9.2 Supply voltage connection**

Preferably from the vehicle's central electrical system.

An additional blade terminal fuse holder is to be installed to protect the heater (supplied with the heater). The fuse holder must only be installed in the vehicle interior.

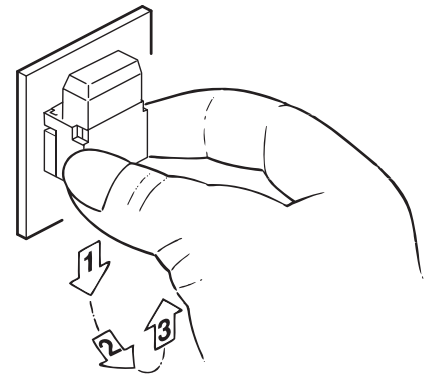

Fig. 811 Removing mounting plate on fuse holder

F = 15A  
(12V and 24V)

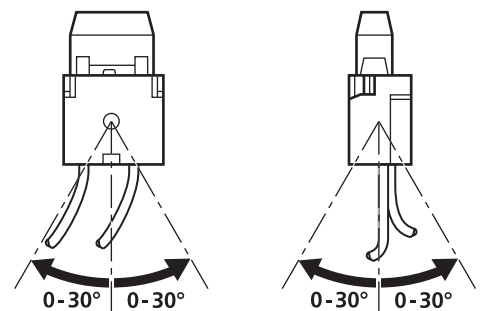

Fig. 812 Fuse holder, installation position

### 8.6.9.3 Control element connection

The wiring harness is prepared for connection to the control element (rotary switch).

Only pull on the connector housing to unplug the connector (Fig. 813).

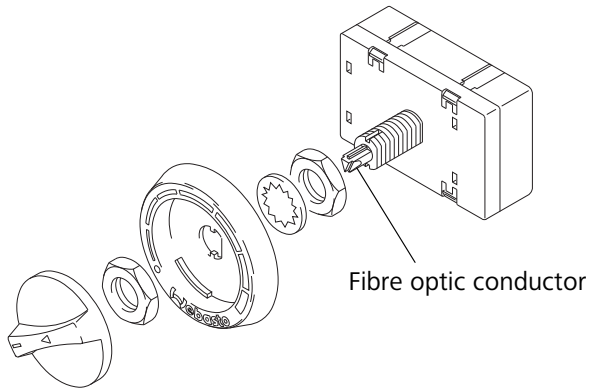

Fig. 813 Rotary switch control element

#### NOTE

The fibre optic cable must make contact with the rotary knob.

#### NOTE

The connector housing will lock (self-locking action) by pulling on the wiring harness.

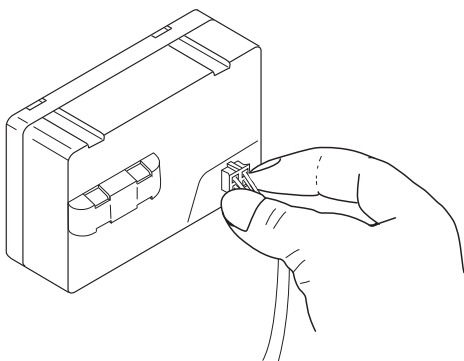
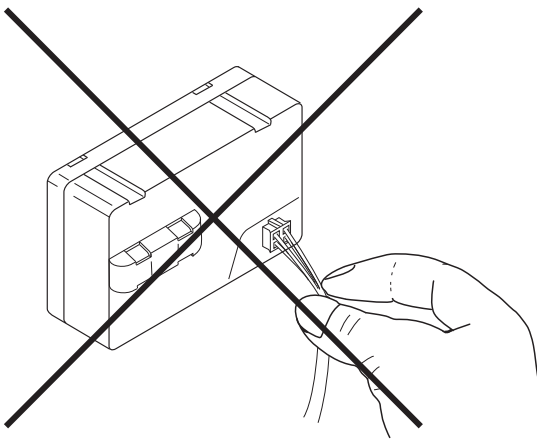

Fig. 814 Disconnecting the connector

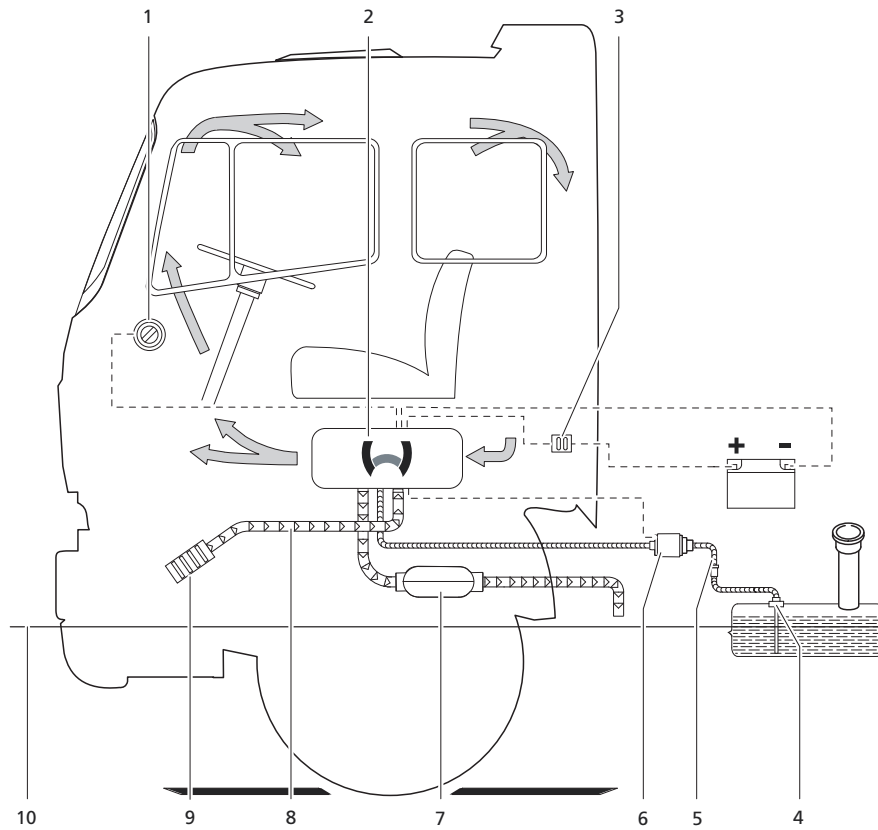

Fig. 815 Installation example of heater in recirculated air mode

- 1 Control element
- 2 Heater
- 3 Fuse
- 4 Tank extracting device
- 5 Fuel filter (accessory)
- 6 Fuel pump
- 7 Exhaust silencer (accessory)
- 8 Combustion air intake line
- 9 Combustion air intake silencer (accessory)
- 10 Maximum permissible fording level

**8.7 Removing and installing****ATTENTION**

The heater must not be dismantled when installed.

**8.7.1 Removing and installing heater****8.7.1.1 Removal**

1. Disconnect vehicle battery.
2. Detach cover from upper casing as shown in 9.2.1.1.
3. Disconnect wiring harness connector from control unit.
4. Disconnect cable to fuel pump at the disconnection point.
5. If necessary, disconnect the heating air hose(s).
6. Undo fuel inlet connection at heater.
7. Undo combustion air inlet and exhaust outlet connections at heater.
8. Remove the four nuts and lock washers on the heater.
9. Remove heater and base seal at the exhaust outlet.

**8.7.1.2 Installation**

1. Place heater with a **new** base seal at the exhaust outlet in the installation position and secure with 4 nuts and lock washers (only use genuine Webasto nuts).
2. Tighten nuts to 6 +1 Nm.
3. Secure fuel inlet connection at heater.
4. Secure combustion air inlet and exhaust outlet connections at heater.
5. Connect fuel pump cable to fuel pump wiring harness.
6. Connect wiring harness connector to socket X6 at the control unit.
7. Reattach and lock cover.
8. If necessary, connect and secure heating air hose(s).
9. Connect vehicle battery.
10. Bleed the fuel supply system (see 8.8).

**8.8 Commissioning**

Carefully bleed the fuel supply system after installing the heater.

**NOTE**

Due to the low fuel consumption, it is necessary to switch on the heater several times to fill the fuel line.

Trial run the heater to check all connections for leaks and to make sure they are secure. If the heater encounters a fault during operation, perform the troubleshooting procedure to locate the malfunction.

Page for notes

## 9 Repair

### 9.1 General information

This section describes the repair jobs that can be carried out on the Air Top 2000 STC heater after it has been removed from the vehicle. Any further dismantling will invalidate the warranty. For assembling the heater only use the spare parts from the corresponding spare parts kits.

#### 9.1.1 Work on stripped down components

##### ATTENTION

All sealing elements between the stripped down components and the seal on the exhaust outlet must always be discarded and renewed.

##### 9.1.1.1 Cleaning

- Clean all stripped down components with benzene and then dry them with compressed air.
- Using a suitable tool, carefully remove all remains of seals on the components.

##### 9.1.1.2 Visual inspection

- Check all components for damage (cracks, deformation, wear, etc.) and replace as required.
- Inspect the connectors and cables for corrosion, loose contacts, crimping faults, etc. and repair as required.
- Check plug strips for corrosion and contacts to ensure they are secure. Repair if necessary.

#### 9.1.2 Carrying out modifications

##### NOTE

The constant development and optimisation of our heaters are aimed at preventing failures and malfunctions. It is generally possible to modify heaters that are already in use. Corresponding modification kits are available for this purpose.

The following describes the modification that can be easily carried out as part of standard repair work:

- Installation of an external room temperature sensor for better temperature control (see 9.1.2.1).

#### 9.1.2.1 Installing of an external room temperature sensor

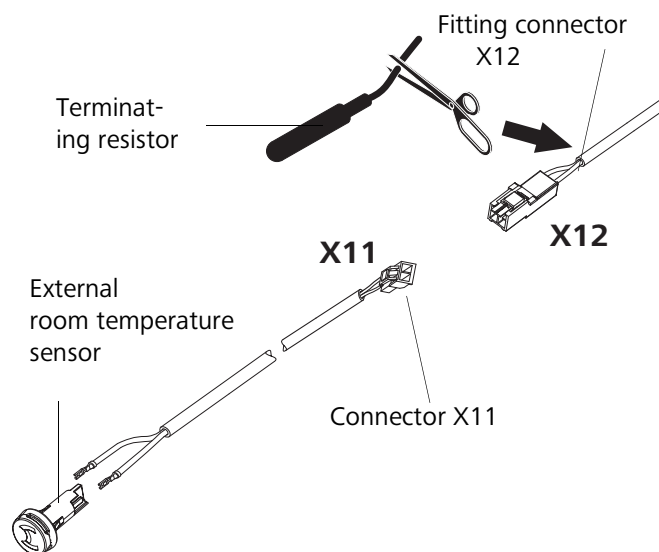

Fig. 901 Installing an external room temperature sensor

##### General information

The heater optimally regulates the required temperature when the air temperature in the area mainly occupied is registered by the room temperature sensor. Due to given installation conditions (addition of fresh air) this may not always be possible with the room temperature sensor integrated in the control unit. In this case, optimum temperature control can be ensured by using an external room temperature sensor fitted in the appropriate area.

##### Procedure

1. Select a suitable position for the external room temperature sensor.

##### NOTE

- The external room temperature sensor should not be mounted directly exposed to hot air and not too close to heat sources (e.g. vehicle heating system).
- The external room temperature sensor should be installed at medium height in the vehicle cabin on vertical surfaces.
- The installation location should not be exposed to direct sunlight.
- Do not install the external room temperature sensor behind curtains or similar.

2. Provisionally install the external room temperature sensor and route the cable to the control element.
3. Cut off the terminating resistor on the heater wiring harness.
4. Crimp connector X12 for the external room temperature sensor onto the end of the cable on the heater wiring harness.

5. Plug connector X12 of the external room temperature sensor into connector X11 of the wiring harness.
6. Plug both connectors on the external room temperature sensor line into the external room temperature sensor.
7. Mount external room temperature sensor.
6. Carry out test run and check the control characteristics

## 9.2 Dismantling and assembling

### 9.2.1 Removing casing parts

#### 9.2.1.1 Cover for electrical connection

The cover (1, Fig. 902) can be carefully levered off using a blunt blade in the areas marked (X).

#### 9.2.1.2 Grille for heating air inlet and outlet

The grilles (5) can be released by twisting and then detached by pulling forward.

#### 9.2.1.3 Cover for heating air inlet and outlet

Both covers (3 and 6, Fig. 902) can be released from their mounting and removed by pressing the 4 retaining lugs at the top and bottom using a suitable tool.

#### 9.2.1.4 Upper casing

##### NOTE

The covers for heating air inlet and outlet must have been removed.

The casing (2, Fig. 902) can be removed by pulling upwards.

#### 9.2.1.5 Lower casing

The retainer is released by gently pulling the lower casing (4, Fig. 902) on both sides in areas (Y) and the casing can then be detached from the motor.

### 9.2.2 Fitting the casing parts

#### 9.2.2.1 Lower casing

##### ATTENTION

To ensure effective operation of the heater and the overheating temperature sensor, observe the following points when installing the casing:

- Four insulators are used as spacers between the heat exchanger and casing parts.
- Slide the four insulators (7, Fig. 902) onto the four corner fins of the heat exchanger and position them exactly next to the wide area of the fins.
- Make sure that all four insulators (7, Fig. 902) are firmly seated.

##### ATTENTION

When fitting the lower casing (4, Fig. 902), spread it slightly so that the spacers on the overheating temperature sensor (8, Fig. 903) are not damaged.

1. Gently spread the lower casing (4, Fig. 902) and fit it onto the heater from below so that the lock pins in the heater engage in the holes in the casing.
2. Fit new seal on the exhaust outlet.

#### 9.2.2.2 Upper casing

1. Place the upper casing (2, Fig. 902) on the heater and secure it in the grooves in the lower casing.

#### 9.2.2.3 Cover for heating air inlet and outlet

##### NOTE

The covers for heating air inlet and outlet are different. Fit the cover with the smaller opening in the end face on the heating air fan.

1. Push on covers (3 and 6, Fig. 902) until the 4 securing holes engage properly over the retaining lugs on the lower and upper casing.

#### 9.2.2.4 Grille for heating air inlet and outlet

1. Fit the grilles (5, Fig. 902) onto the covers for heating air inlet and outlet and lock by twisting.

#### 9.2.2.5 Cover for electrical connection

##### NOTE

Corresponding to given installation conditions, the wiring harness leads out of the left or right of the heater.

1. Slide on cover (1, Fig. 902) until it audibly snaps into the upper casing.

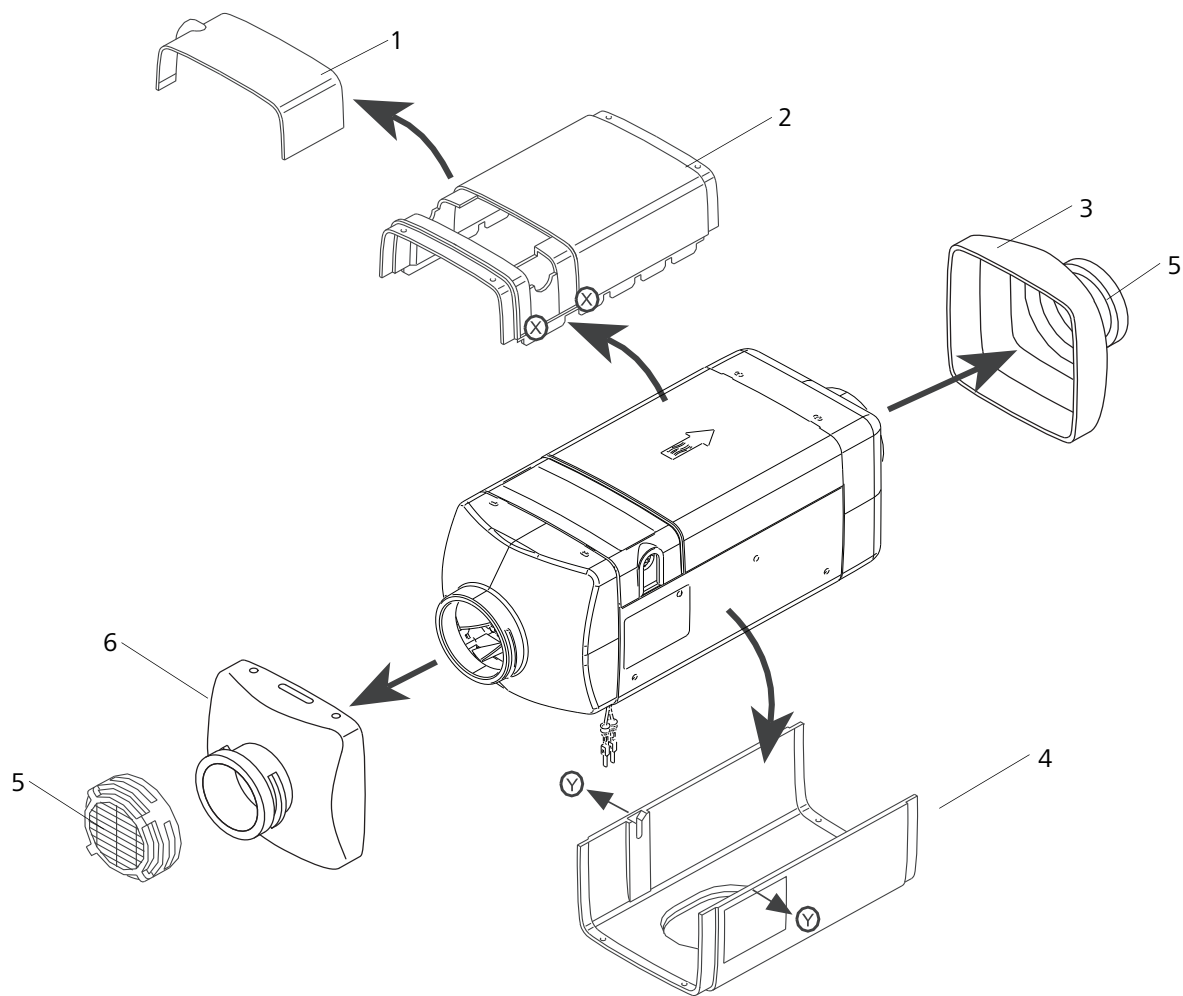

- 1 Cover, electrical connection
- 2 Upper casing
- 3 Cover, heating air outlet
- 4 Lower casing
- 5 Grille
- 6 Cover, heating air inlet
- 7 Insulator

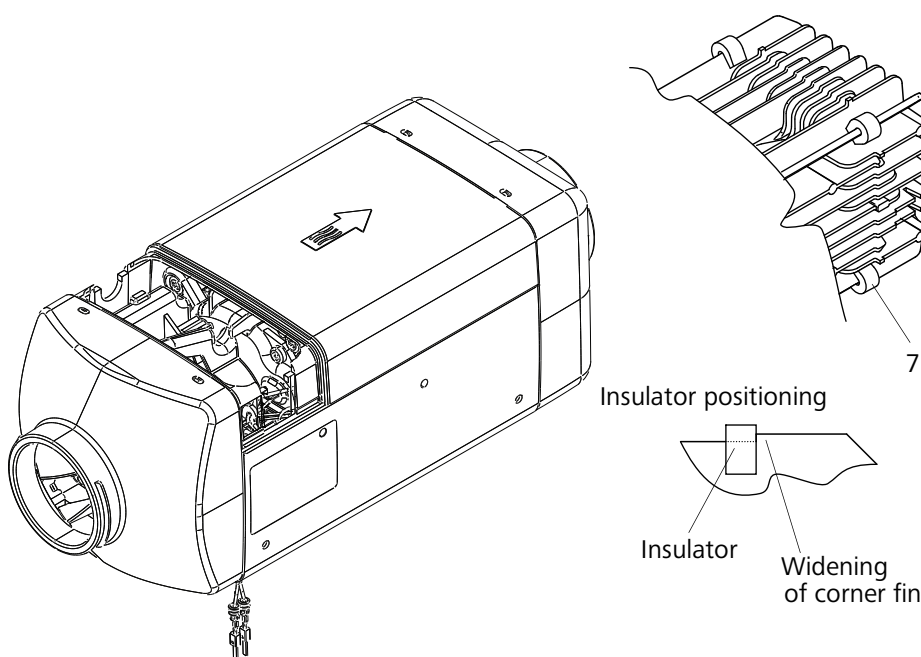

Fig. 902 Removing / fitting casing parts



### 9.2.3 Replacing control unit

#### 9.2.3.1 Removal

1. Remove heater (see 8.7.1.1).
2. Remove casing parts (see 9.2.1).
3. Spread apart heating air fan retainer.
4. Pull off the heating air fan (1, Fig. 903) from the motor shaft by hand.
5. Disconnect plug connections at control unit (3).
6. Remove screws (2) and remove control unit (3).
7. Complete work on stripped down components (see 9.1.1).

#### NOTE

Do not carry out any repairs to the control unit.

#### 9.2.3.2 Installation

1. Place control unit (3, Fig. 903) in installation position and secure with screws (2).
2. Tighten screws to  $0.7 \pm 0.07$  Nm.
3. Slide heating air fan (1) onto the motor shaft until the lugs on either side can be heard to engage in the shaft groove.
4. Connect plugs to sockets at control unit (3) as shown in Abb. 701.
5. Reattach casing parts (see 9.2.2).
6. Install heater (see 8.7.1.2).
7. Check CO<sub>2</sub> setting and adjust if necessary (see 6.3).
8. Turn heating air fan by hand to check that it turns smoothly and listen for any noises when subsequently switched on.  
Sensor magnets on the heating air fan must be free of metal chips etc.

### 9.2.4 Replacing the overheating temperature sensor

#### 9.2.4.1 Removal

1. Remove heater (see 8.7.1.1).
2. Remove casing parts (see 9.2.1).
3. Remove insulators (9, Fig. 903).
4. Disconnect plug connection X5 at control unit (3).

#### ATTENTION

Do not pull the wires.

5. Use a suitable tool to lever overheating temperature sensor (8) out of the heat exchanger fins (7) (see Detail A).
6. Remove overheating temperature sensor (8).

#### 9.2.4.2 Installation

1. Measure resistance of overheating temperature sensor (8, Fig. 903) (see 6.4.5).
2. Place overheating temperature sensor (8) in installation position on heat exchanger (7) and press in by hand.

#### ATTENTION

There must be no electrical connection between the sensor and the sheet metal holder.

3. Make sure that the overheating temperature sensor is positioned correctly in the heat exchanger (7).
4. Connect plug connection X5 to control unit (3).  
Ensure the wires are routed parallel between the fins of the heat exchanger.
5. Fit insulators (9) onto heat exchanger.
6. Reattach casing parts (see 9.2.2).
7. Install heater (see 8.7.1.2).

### 9.2.5 Replacing drive unit (drive motor, combustion air fan and intake housing)

#### 9.2.5.1 Removal

1. Remove heater (see 8.7.1.1).
2. Remove casing parts (see 9.2.1).
3. Remove control unit (see 9.2.3.1).

#### NOTE

A total of 9 screw heads can be seen (see 5, Fig. 903). The 5 outer screws serve to secure the intake housing to the heat exchanger (7). Only these screws are to be removed.

4. Remove screws (4).
5. Pull drive unit (5) from heat exchanger (7), remove and dispose of gasket (6).
6. Complete work on stripped down components (see 9.1.1).

#### 9.2.5.2 Installation

1. Make sure that the sealing surfaces on the intake housing (5, Fig. 903) and on the heat exchanger (7) are not damaged.
2. Place a new gasket (6) on flange of intake casing (5).
3. Fit drive unit (5) in assembly position and secure with screws (4) while also securing the earth connection of the wiring harness to the drive motor.
4. Tighten screws (4) to  $6 \pm 0.6$  Nm.
5. Install control unit (see 9.2.3.2).
6. Reattach casing parts (see 9.2.2).
7. Install heater (see 8.7.1.2).
8. Check CO<sub>2</sub> setting and adjust if necessary (see 6.3).

**9.2.6 Replacing flame monitor (petrol heater only)****9.2.6.1 Removal**

1. Remove heater (see 8.7.1.1).
2. Remove casing parts (see 9.2.1).
3. Remove control unit (see 9.2.3.1).
4. Remove drive unit (see 9.2.5.1).
5. Remove two screws (2, Fig. 903) and air baffle (3).
6. Press cable grommet (11) at flame monitor cable inwards and out of heat exchanger (9).
7. Carefully bend back retaining clip (4) and pull flame monitor (1) out of burner.
8. Remove flame monitor.
9. Complete work on stripped down components (see 9.1.1).

**9.2.6.2 Installation****ATTENTION**

Route cable of flame monitor under the fuel line.

1. Push flame monitor (1, Fig. 904) through under the fuel line, guide the connector through the hole in heat exchanger (9) and press cable grommet (11) from the inside into the heat exchanger (9).
2. Route cable with protective sheathing through retaining clip (4) and fit flame monitor (1) in burner (5).
3. Press retaining clip (4) back together.
4. Secure air baffle (3) with screws (2).
5. Tighten screws (2) to  $6 \pm 0.6$  Nm.
6. Pull cable of flame monitor taut.
7. Install drive unit (see 9.2.5.2).
8. Install control unit (see 9.2.3.2).
9. Reattach casing parts (see 9.2.2).
10. Install heater (see 8.7.1.2).

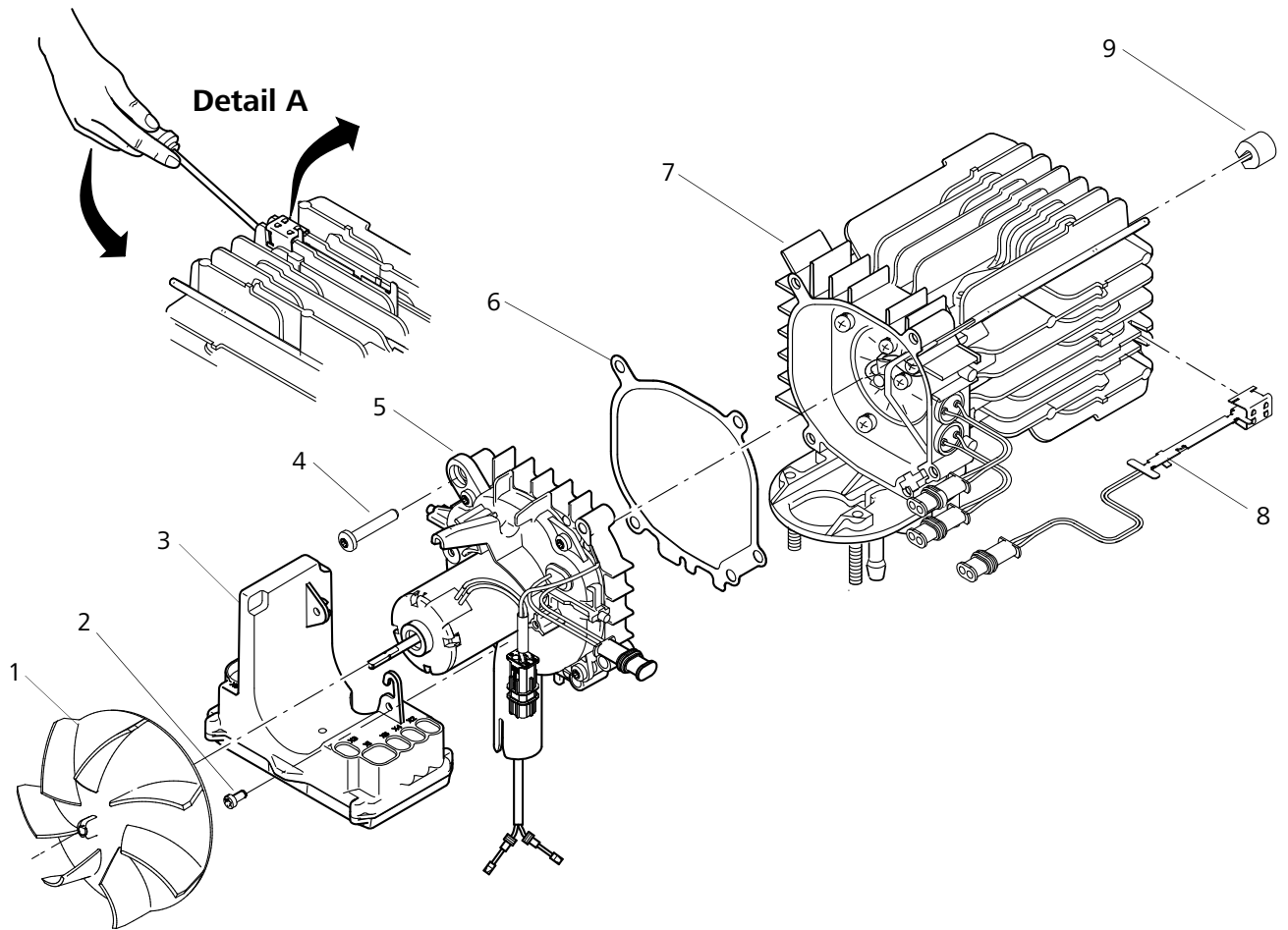

- 1 Heating air blower
- 2 Torx screw (3)
- 3 Control unit
- 4 Torx screw (5)
- 5 Drive motor, combustion air fan and intake housing
- 6 Gasket
- 7 Heat exchanger
- 8 Overheating temperature sensor
- 9 Isolator (4)

Fig. 903 Replacing control unit, combustion air fan and overheating temperature sensor

**9.2.7 Changing glow plug****9.2.7.1 Removal**

1. Remove heater (see 8.7.1.1).
2. Remove casing parts (see 9.2.1).
3. Remove control unit (see 9.2.3.1).
4. Remove combustion air fan (see 9.2.5.1).
5. Press cable grommet (10, Fig. 904) inwards and out of heat exchanger (9).
6. Remove four screws (2) and air baffle (3).

**NOTE**

Make sure that the burner (5) has detached from combustion chamber (13).

7. Tilt and carefully pull out burner (5).

**ATTENTION**

The glow plug must be removed with the utmost care and must not be twisted (risk of breakage). After lengthy operation of the burner, fuel deposits may have caused the glow plug to seize. In this case apply penetrating oil and allow to work in until the glow plug can be removed.

8. Undo screw (7) and pull glow plug (6) out of burner.
9. Remove combustion chamber (13) and gasket (12) from heat exchanger (9) and dispose of gasket.
10. Complete work on stripped down components (see 9.1.1).

**9.2.7.2 Installation**

1. Fit new gasket (12, Fig. 904) in heat exchanger (9) and place combustion chamber (13) in assembly position.
2. Make sure that the starting air hole in the burner (5) is clear.  
If necessary clean with approx. 4 mm Ø wire (see Fig. 905).

**ATTENTION**

When installing the glow plug make sure that the contacts point towards the heat exchanger. Otherwise there is a risk of short-circuiting.

3. Insert glow plug (6) in the burner (5) and fit protective cable sheathing in the slot in the burner.

**ATTENTION**

In the following procedure make sure that the glow plug is fitted up to the stop in the burner.

4. Secure glow plug (6) with screw (7). Tighten screw (7) to 0.5 Nm.
5. Fit burner (5) in heat exchanger (9). Make sure that the cable of flame monitor (1) (for petrol heater only) is positioned under the fuel line.
6. Pass connectors of the glow plug and of the flame monitor through the holes and press cable grommets (10) into the heat exchanger.

**ATTENTION**

In the following procedure make sure that the grommet (8) seals off tight with the heat exchanger (9).

7. Secure burner (5) and air baffle (3) with screws (2). Tighten screws (2) to  $6 \pm 0.6$  Nm.
8. Install combustion air fan (see 9.2.5.2).
9. Install control unit (see 9.2.3.2).
10. Reattach casing parts (see 9.2.2).
11. Install heater (see 8.7.1.2).

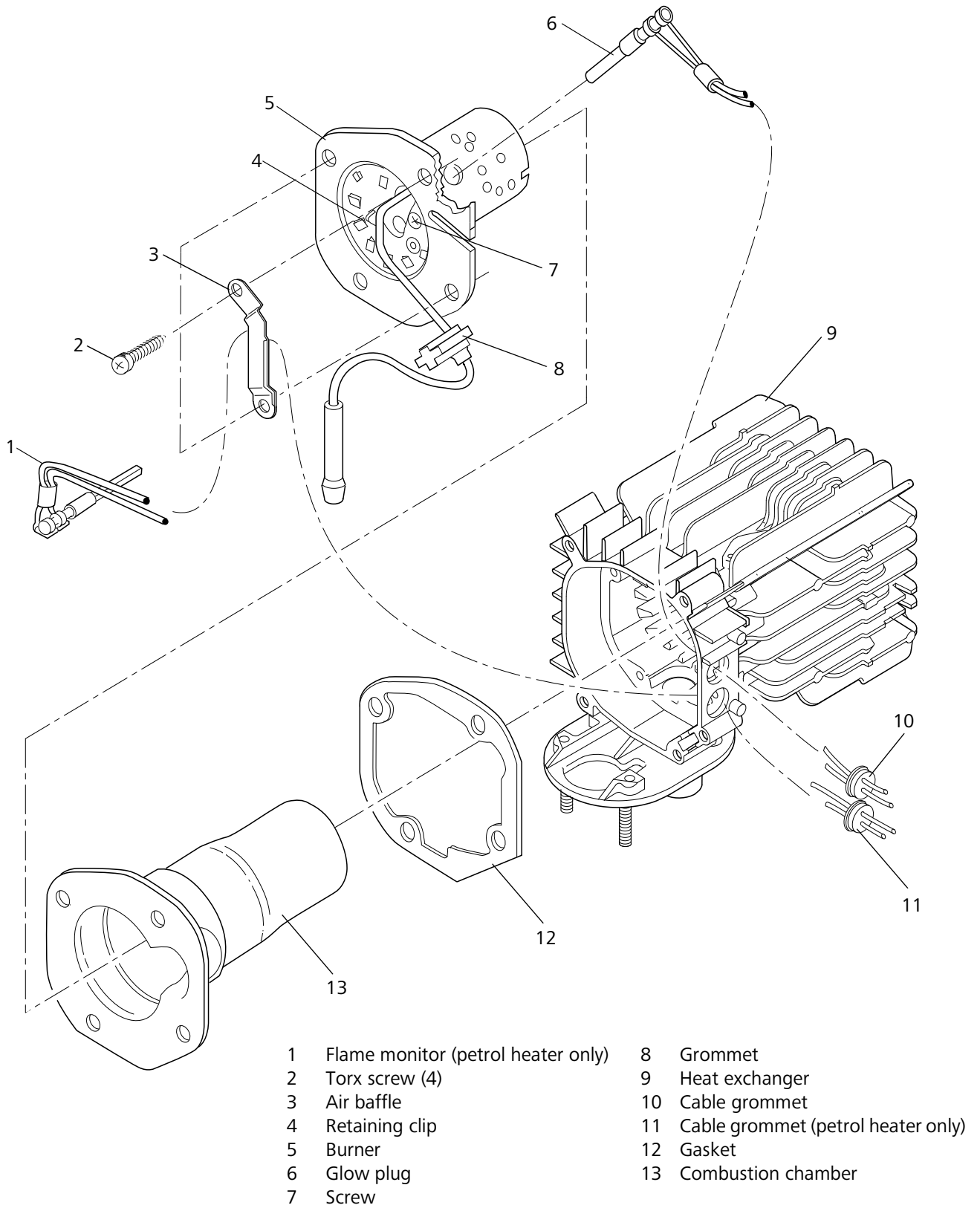

Fig. 904 Changing glow plug, replacing flame monitor, burner and heat exchanger

### **9.2.8 Replacing burner, combustion chamber and heat exchanger**

#### **9.2.8.1 Removal**

1. Remove heater (see 8.7.1.1).
2. Remove casing parts (see 9.2.1).
3. Remove control unit (see 9.2.3.1).
4. Remove overheating temperature sensor (see 9.2.4.1).
5. Remove combustion air fan (see 9.2.5.1).
6. Remove flame monitor (petrol heater only) (see 9.2.6.1).
7. Remove glow plug (see 9.2.7.1).

#### **ATTENTION**

In the following procedure make sure that the fuel connection is not bent.

8. Remove burner (5, Fig. 904).
9. Remove combustion chamber (13) and gasket (12) from heat exchanger (9) and dispose of gasket (12).
10. Complete work on stripped down components (see 9.1.1).

#### **9.2.8.2 Installation**

1. Fit new gasket (12, Fig. 904) in heat exchanger (9) and place combustion chamber (13) in assembly position.

#### **NOTE**

The burner (5) is secured when installing the flame monitor and glow plug.

2. Fit glow plug (see 9.2.7.2).
3. Install flame monitor (petrol heater only) (see 9.2.6.2).

#### **ATTENTION**

In the following procedure make sure that the fuel connection is not bent.

4. Fit burner (5) in heat exchanger (9). Make sure that the cable of flame monitor is positioned under the fuel line.
5. Secure burner (5) and air baffle (3) with screws (2).
6. Tighten screws (2) to  $6 \pm 0.6$  Nm.
7. Install combustion air fan (see 9.2.5.2).
8. Install control unit (see 9.2.3.2).
9. Install overheating temperature sensor (see 9.2.4.2).
10. Fit insulators (11).
11. Reattach casing parts (see 9.2.2).
12. Install heater (see 8.7.1.2).

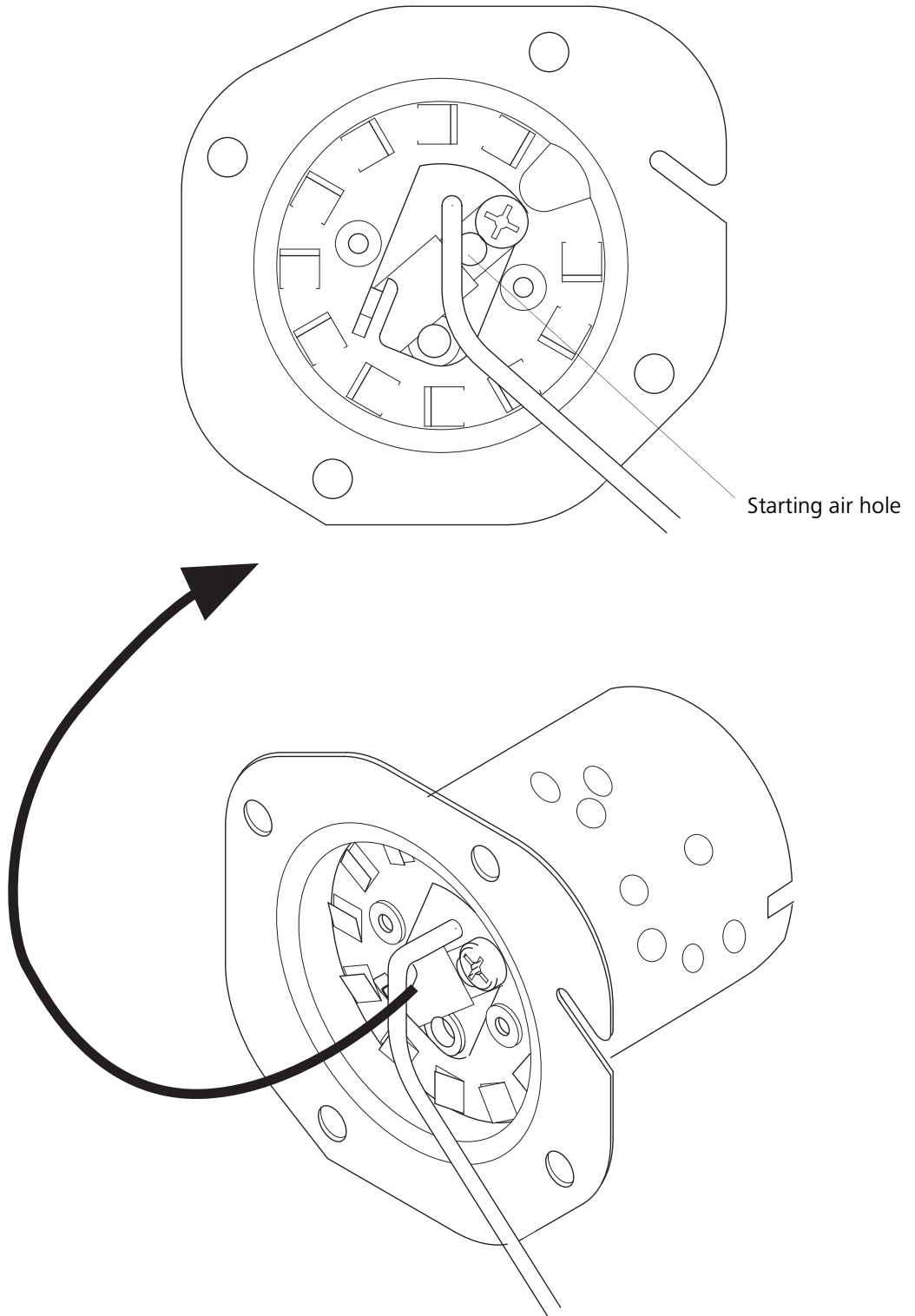

Fig. 905 Starting air hole in burner

## **10 Packaging/storage and shipping**

### **10.1 General information**

If the heater or its components are to be sent to Webasto Thermo & Comfort SE for testing or repair, they must be cleaned and packed in such a way that they are protected from damage during handling, transportation and storage.

During storage an ambient temperature between +85 °C and -40 °C must not be exceeded.

Shipping address:

You will find the address for your Webasto dealer at <http://dealers.webasto.com>.



Page for notes

In multilingual versions the German language is binding.

Webasto Thermo & Comfort SE  
Postfach 1410  
82199 Gilching  
Germany

Visiting address:  
Friedrichshafener Str. 9  
82205 Gilching  
Germany

Internet: [www.webasto.com](http://www.webasto.com)

Technical Extranet: <http://dealers.webasto.com>

The telephone number of each country can be found in the Webasto service center leaflet or the website of the respective Webasto representative of your country.